

---

# Instructions

Philipp Koehn

11 September 2019

HW1 - due Friday 9/13

HW2 - due Friday 9/20

⇓  
digital design



# number adder

# Design Goal



- Build a machine that adds several numbers together
- Numbers stored in 64 KB RAM
- Idea: Loop through memory with ripple counter

# 64 KB RAM

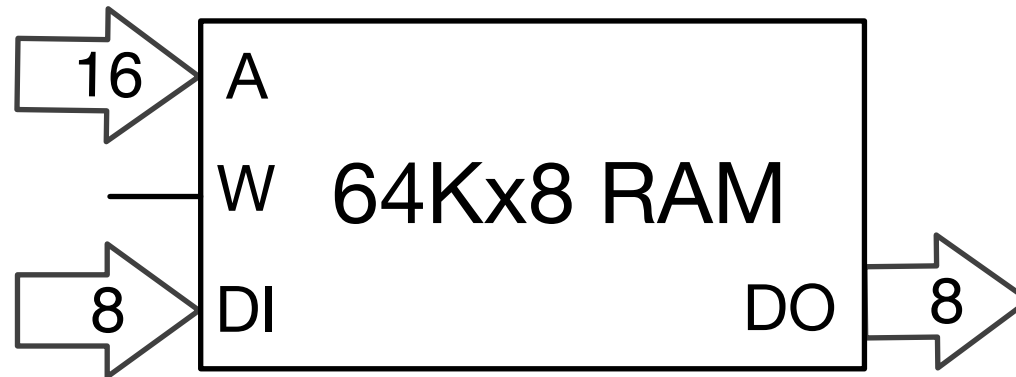

- Read/write 8 bits at a time (one byte)
- 16 bit address space:  $2^{16}=65,536$  bytes

# Control Panel

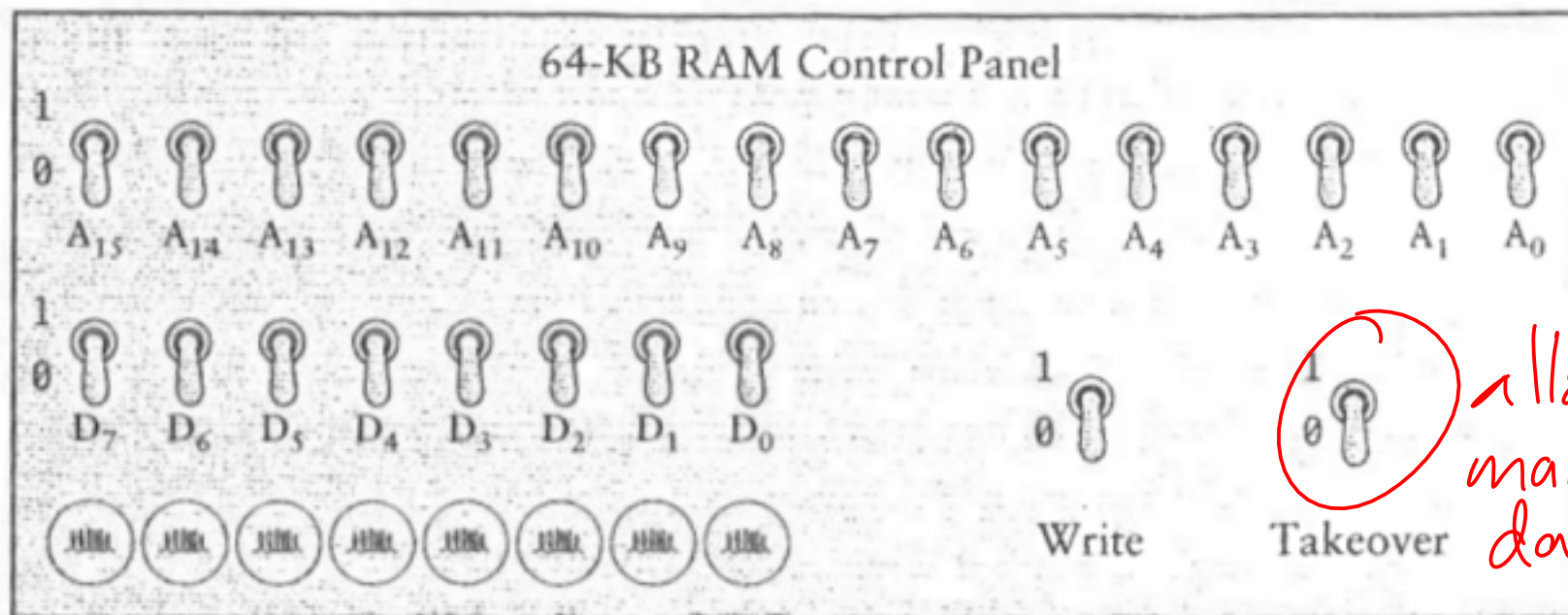

# Control Panel

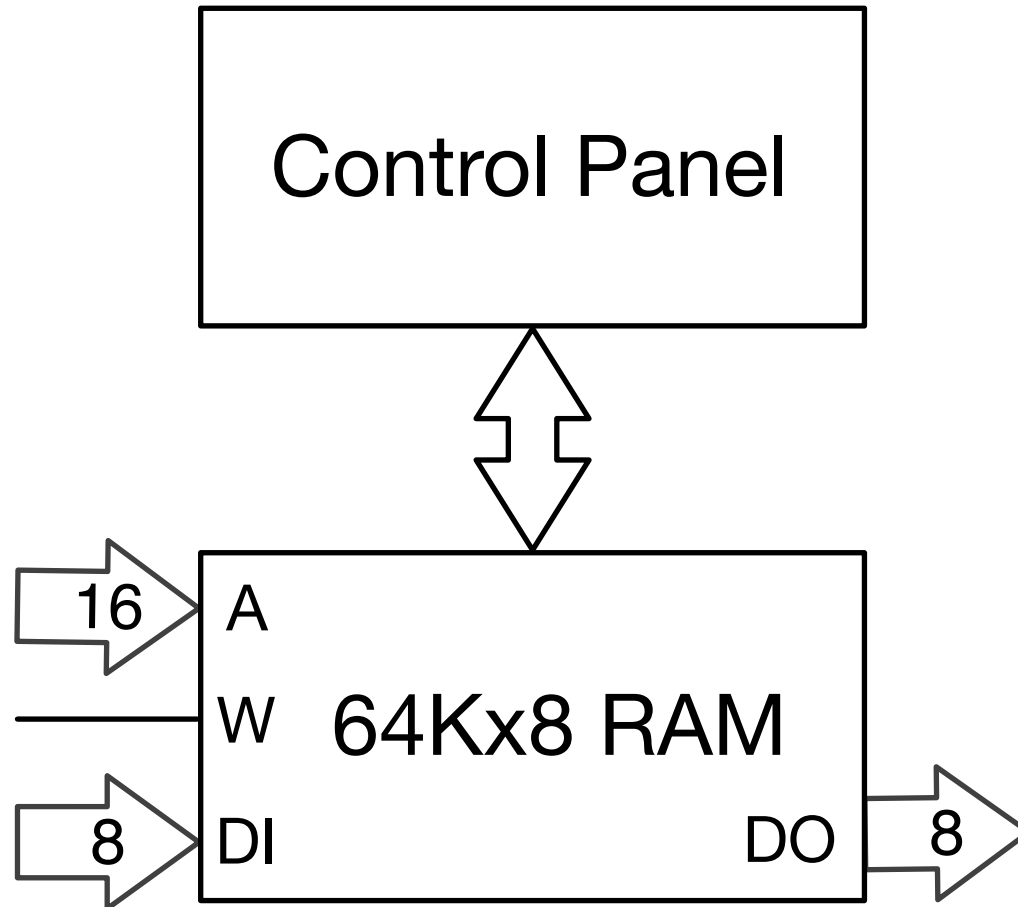

We can enter numbers and inspect with a control panel

# Ripple Counter

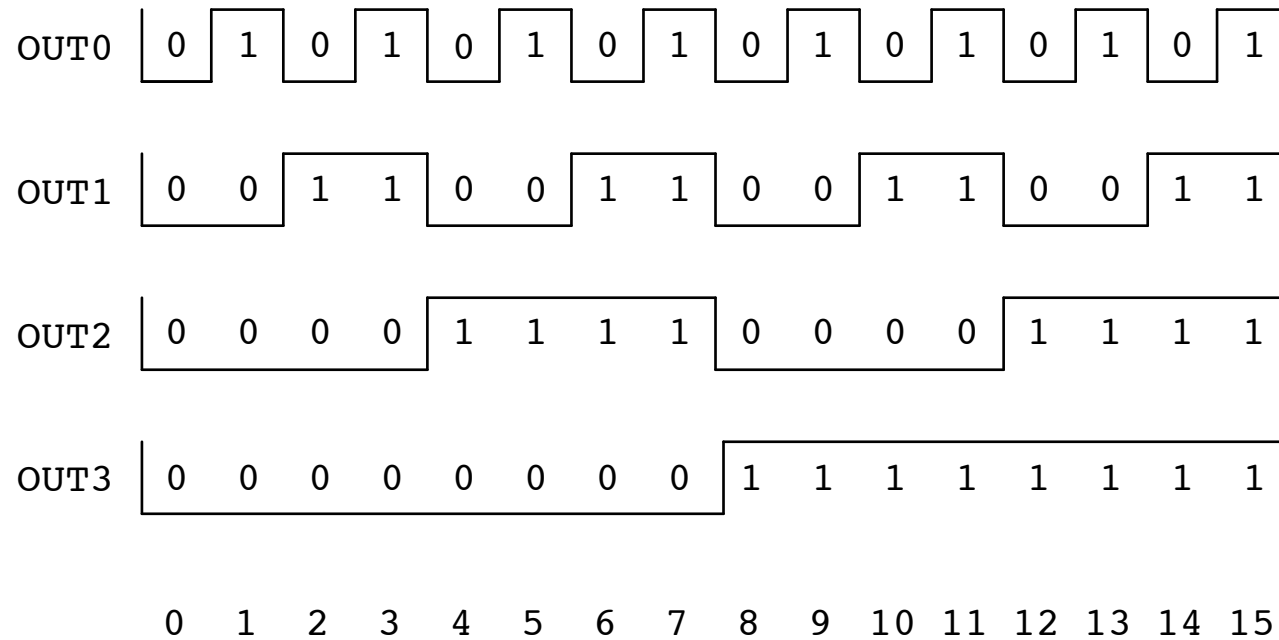
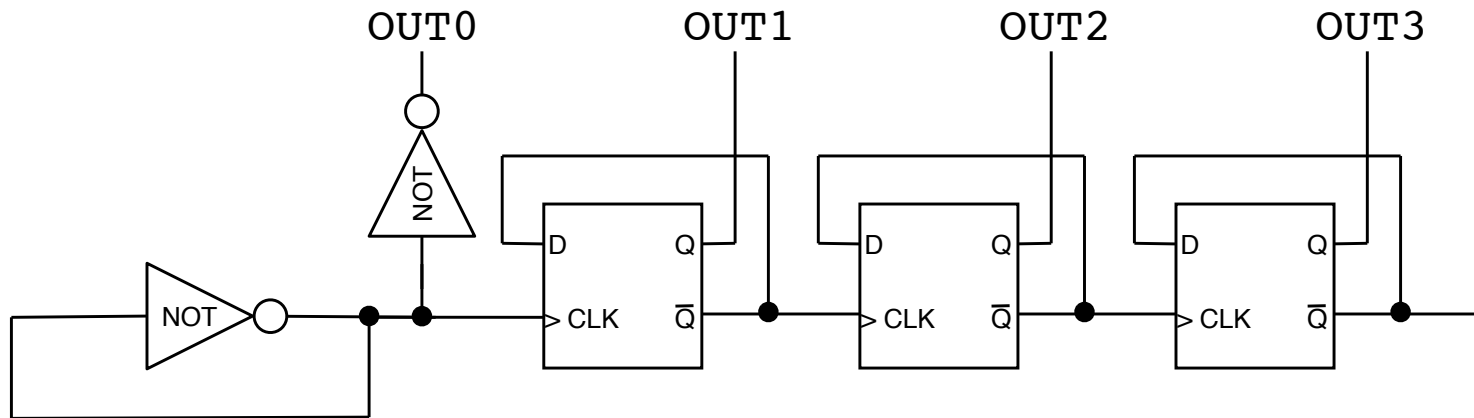

# Connecting Ripple Counter to Memory

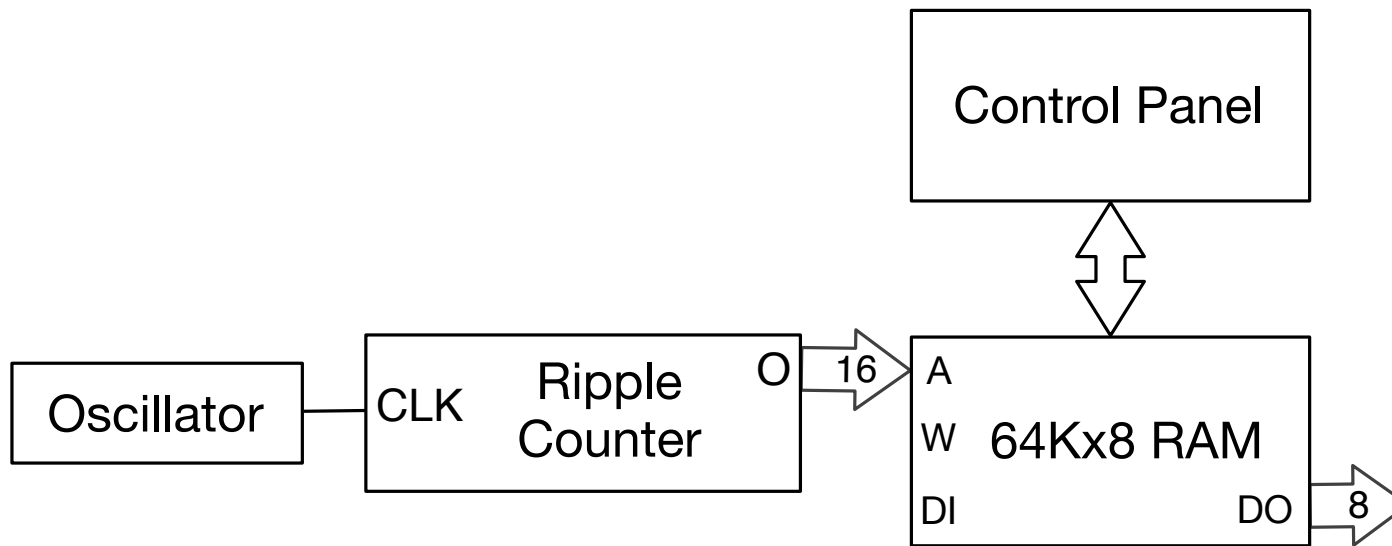

- Ripple counter rotates through number 0, 1, ...
- Each clock cycle, a new number is emitted from memory



# Adder

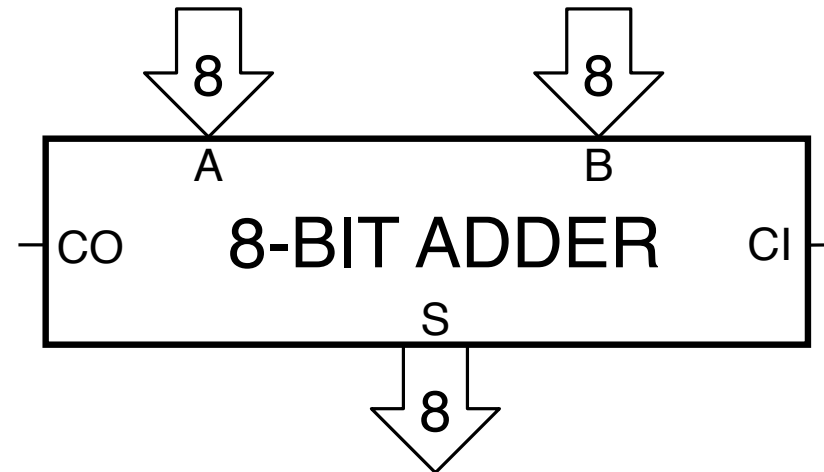

- Adds two numbers:  $S=A+B$
- Overflow: Carry out (CO)

# Latch

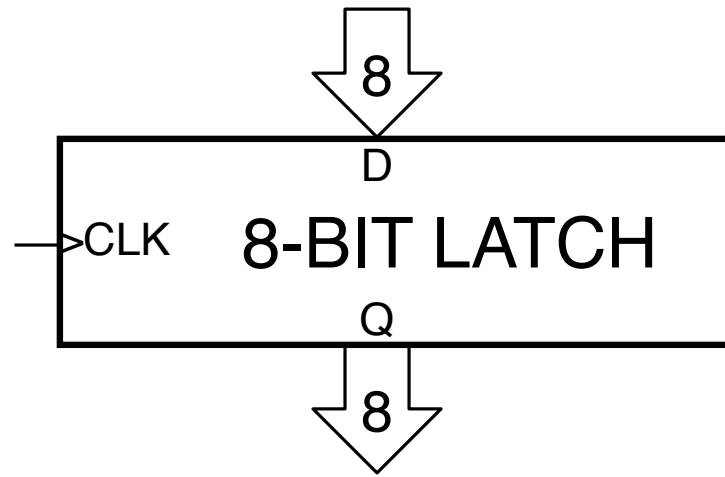

- 8-bit memory
- Edge-triggered: stores value when clock turns to 1
- To be used as accumulator

# Connecting Adder and Latch

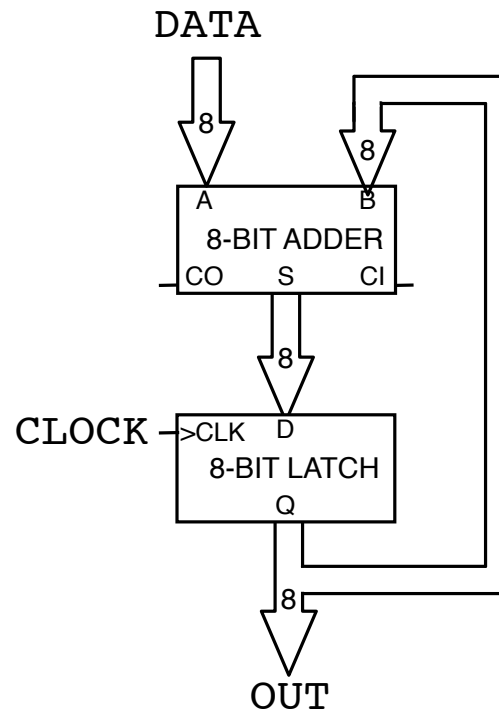

- Adder adds new value (DATA) to accumulator
- Edge trigger prevents immediate feedback
- Output (OUT) may be shown with light bulbs

# Number Adder

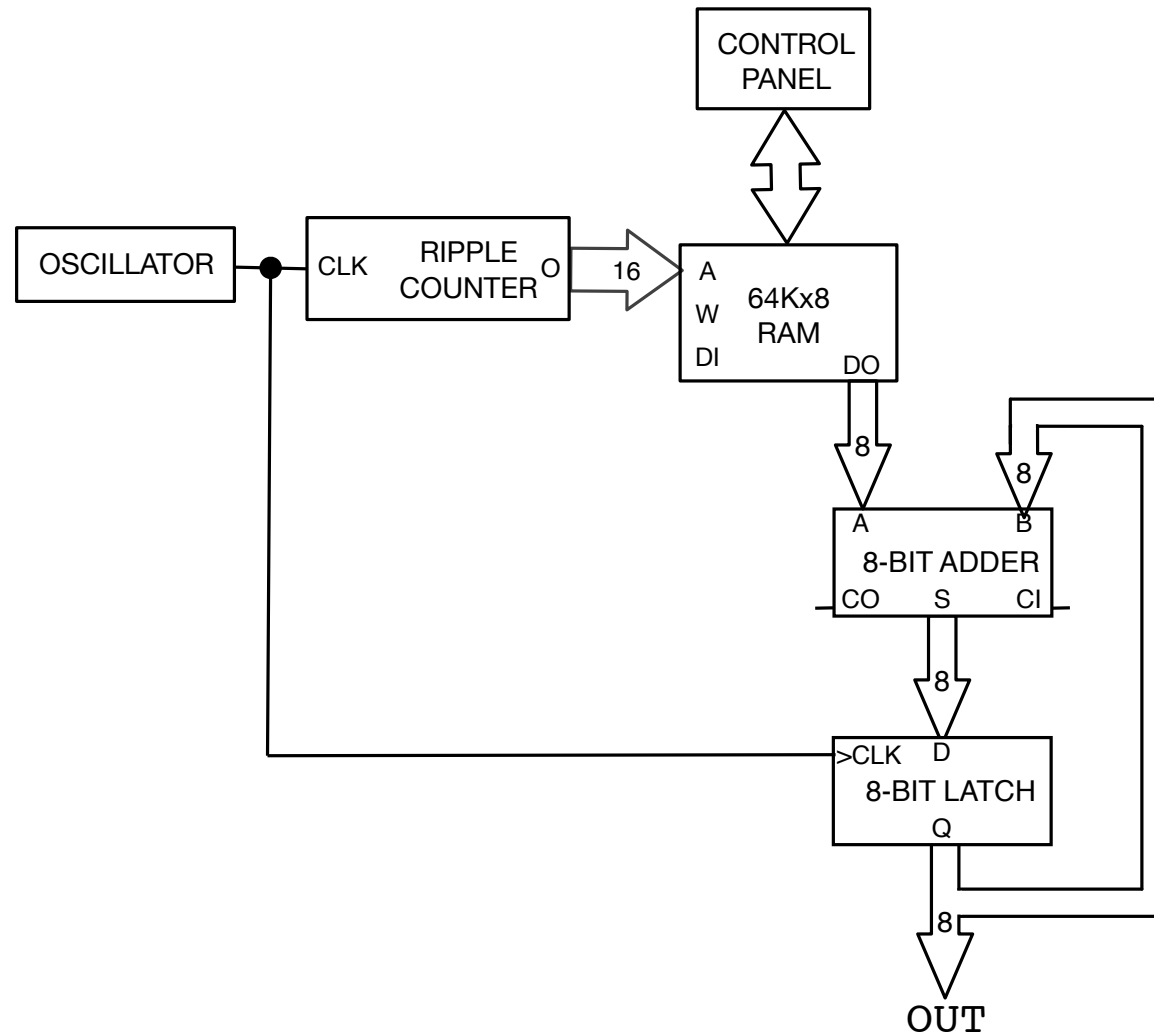

- Everything put together

# Halt

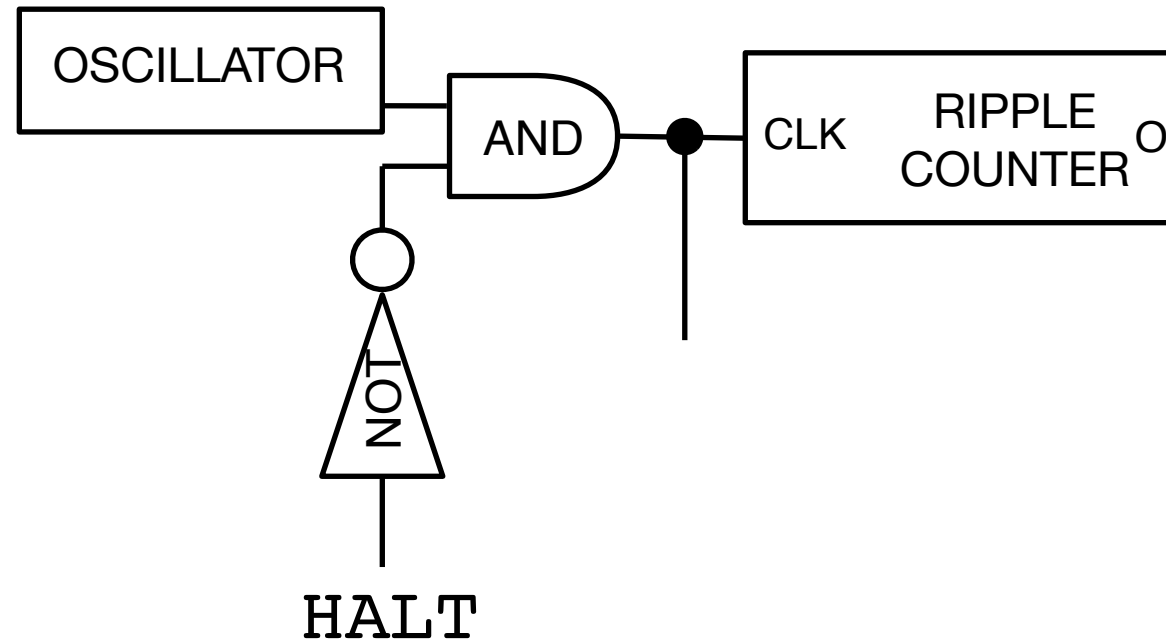

- Halt when external switch is turned on
- Or: cut connection to clock if ripple counter reaches final number



# multiple operations

# Modification: Alternate Add and Subtract



- Let's say we want to alternate between adding and subtracting
- We already built an integrated adder and subtractor

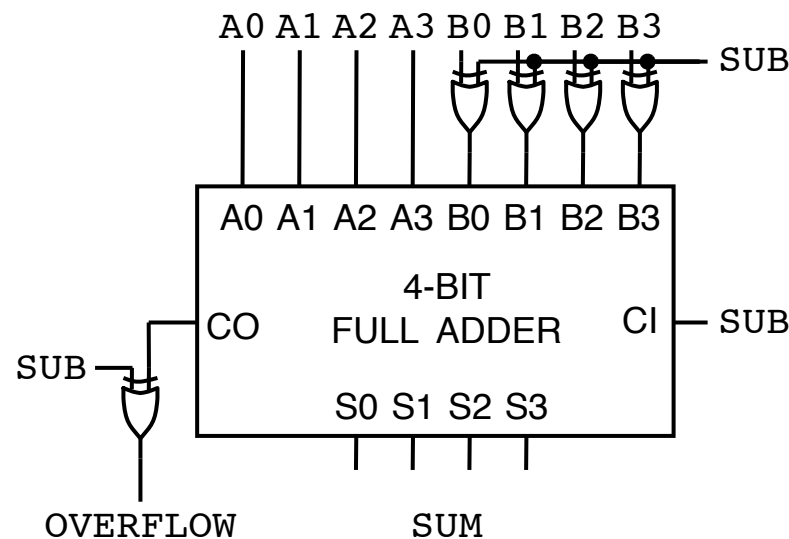

- Idea: indicate operation from last bit of ripple counter

# Alternate Add and Subtract

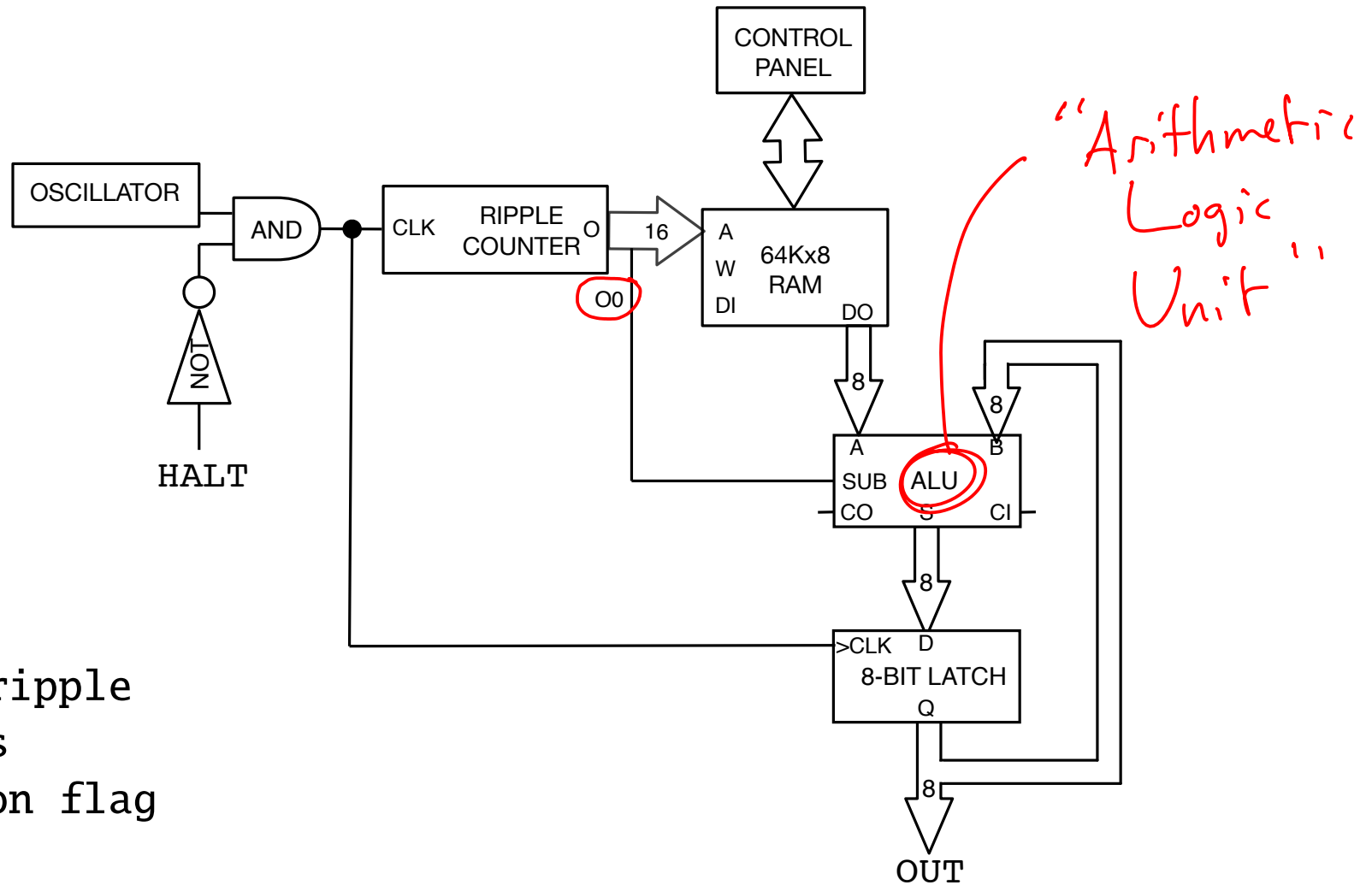

- Bit 0 of ripple counter as instruction flag





# instructions

# Goal



- Control operations by instructions stored in memory

⇒ A *programmable* computer

# Goal

- Control operations by instructions stored in memory

⇒ A *programmable* computer

- First idea
  - separate instruction memory
  - instructions: add or subtract

# Instruction Memory

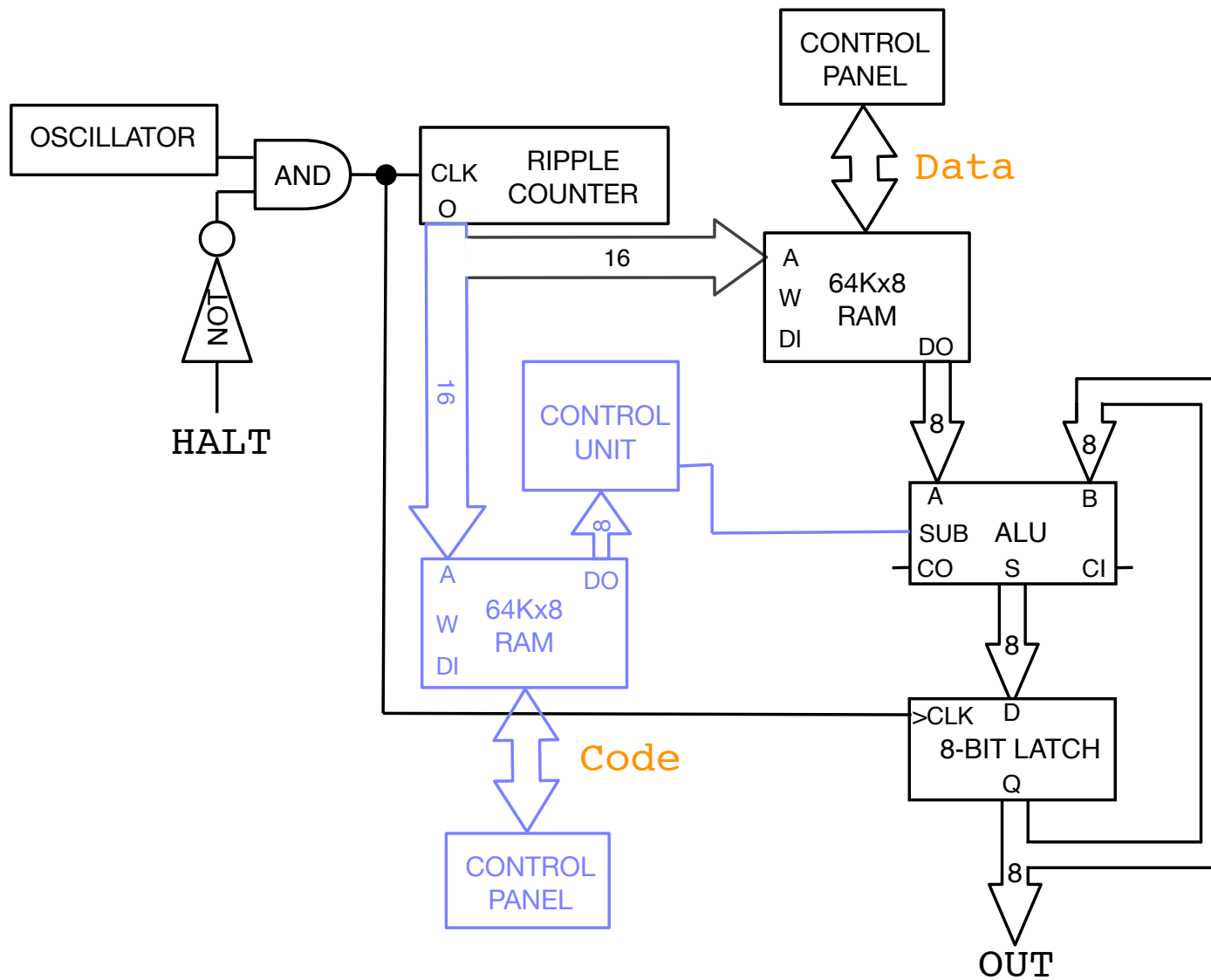

# Operation Codes for Instructions

- Each operation is encoded by a byte value

<b>Operation</b>	<b>Code (hex)</b>
Add	20h
Subtract	21h

# Operation Codes for Instructions

- Each operation is encoded by a byte value

Operation	Code (hex)
Add	20h
Subtract	21h

- Example

Address	Code	Data	Accumulator
0000h	20h Add	01h	
0001h	20h Add	02h	
0002h	21h Subtract	01h	
0003h	20h Add	08h	
0004h	21h Subtract	03h	

# Operation Codes for Instructions

- Each operation is encoded by a byte value

Operation	Code (hex)
Add	20h
Subtract	21h

- Example

Address	Code	Data	Accumulator
			00h
0000h	20h Add	01h	
0001h	20h Add	02h	
0002h	21h Subtract	01h	
0003h	20h Add	08h	
0004h	21h Subtract	03h	

# Operation Codes for Instructions

- Each operation is encoded by a byte value

Operation	Code (hex)
Add	20h
Subtract	21h

- Example

Address	Code	Data	Accumulator
			00h
0000h	20h Add	01h	01h
0001h	20h Add	02h	
0002h	21h Subtract	01h	
0003h	20h Add	08h	
0004h	21h Subtract	03h	



# Operation Codes for Instructions

- Each operation is encoded by a byte value

Operation	Code (hex)
Add	20h
Subtract	21h

- Example

Address	Code	Data	Accumulator
			00h
0000h	20h Add	01h	01h
0001h	20h Add	02h	03h
0002h	21h Subtract	01h	
0003h	20h Add	08h	
0004h	21h Subtract	03h	

# Operation Codes for Instructions

- Each operation is encoded by a byte value

Operation	Code (hex)
Add	20h
Subtract	21h

- Example

Address	Code	Data	Accumulator
			00h
0000h	20h Add	01h	01h
0001h	20h Add	02h	03h
0002h	21h Subtract	01h	02h
0003h	20h Add	08h	
0004h	21h Subtract	03h	

# Operation Codes for Instructions

- Each operation is encoded by a byte value

Operation	Code (hex)
Add	20h
Subtract	21h

- Example

Address	Code	Data	Accumulator
			00h
0000h	20h Add	01h	01h
0001h	20h Add	02h	03h
0002h	21h Subtract	01h	02h
0003h	20h Add	08h	0ah
0004h	21h Subtract	03h	

# Operation Codes for Instructions

- Each operation is encoded by a byte value

Operation	Code (hex)
Add	20h
Subtract	21h

- Example

Address	Code	Data	Accumulator
			00h
0000h	20h Add	01h	01h
0001h	20h Add	02h	03h
0002h	21h Subtract	01h	02h
0003h	20h Add	08h	0ah
0004h	21h Subtract	03h	07h

# Operation Codes for Instructions

- Each operation is encoded by a byte value

Operation	Code (hex)
Add	20h
Subtract	21h

- Example

Address	Code	Data	Accumulator
			00h
0000h	20h Add	01h	01h
0001h	20h Add	02h	03h
0002h	21h Subtract	01h	02h
0003h	20h Add	08h	0ah
0004h	21h Subtract	03h	07h

# More Instructions



- Load: load number from memory into accumulator
- Store: store accumulator value in memory
- Halt: block clock

# Operation Codes for Instructions

- Each operation is encoded by a byte value

<b>Operation</b>	<b>Code (hex)</b>
Load	10h
Store	11h
Add	20h
Subtract	21h
Halt	FFh

# More Wiring

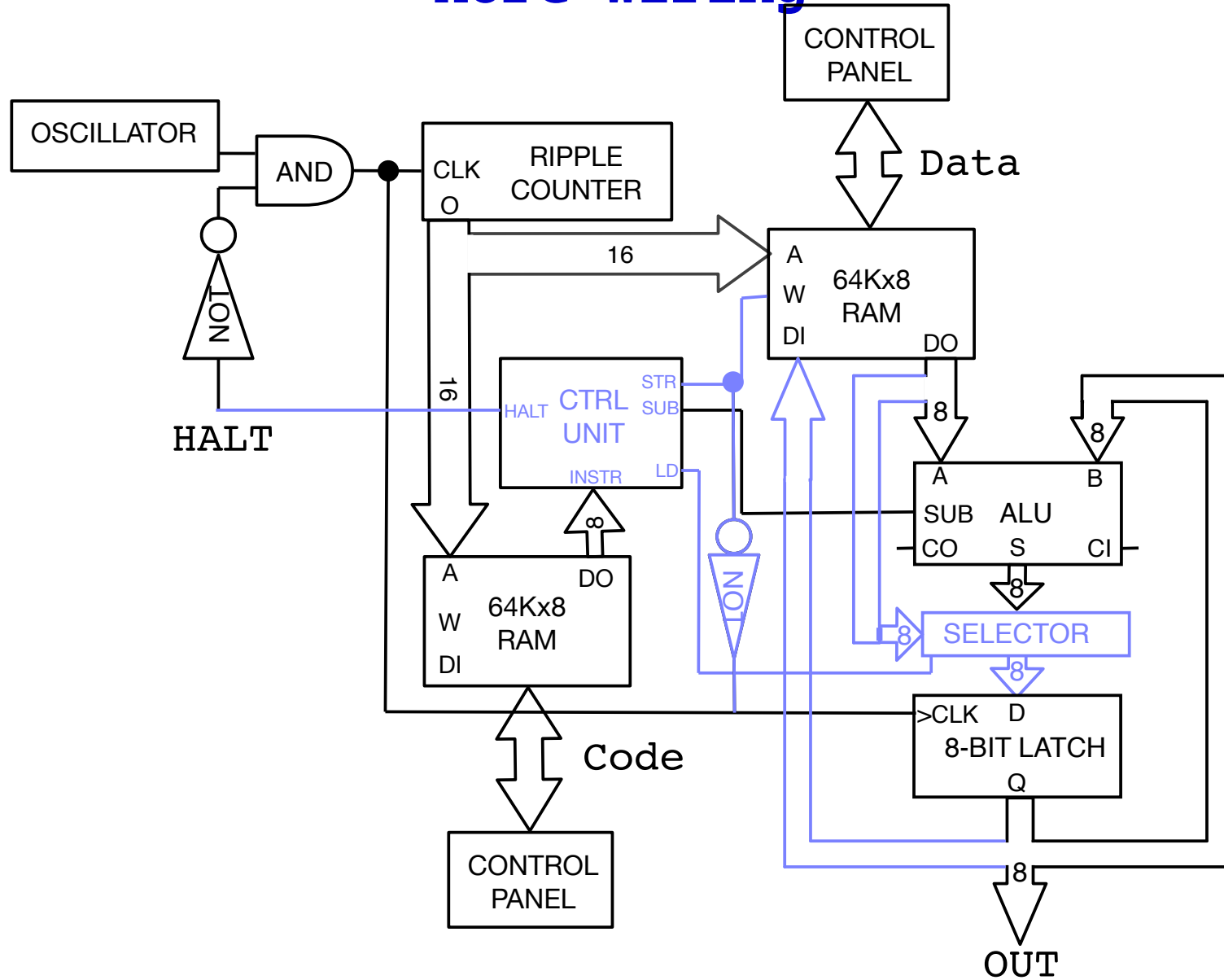



# Load

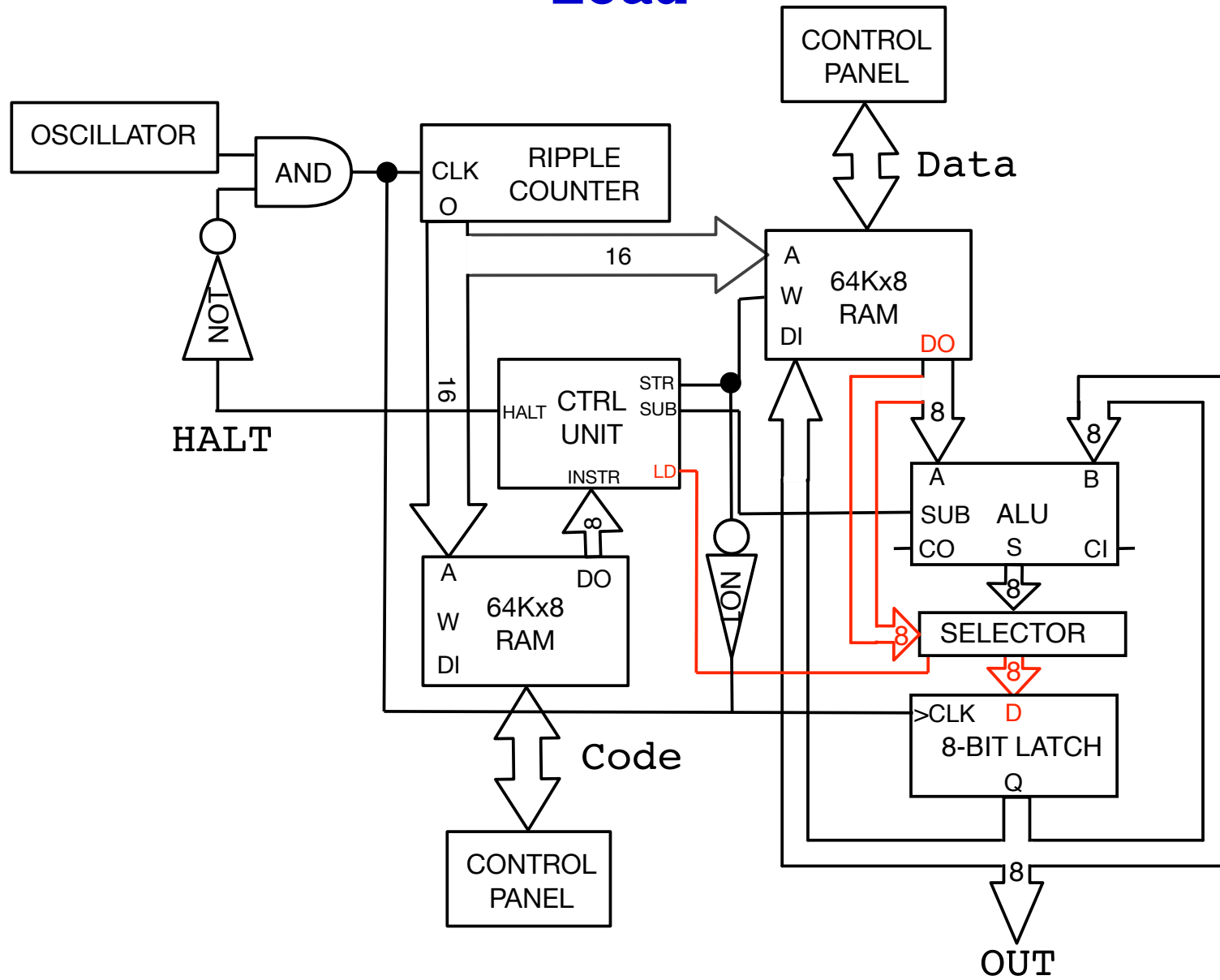

# Store

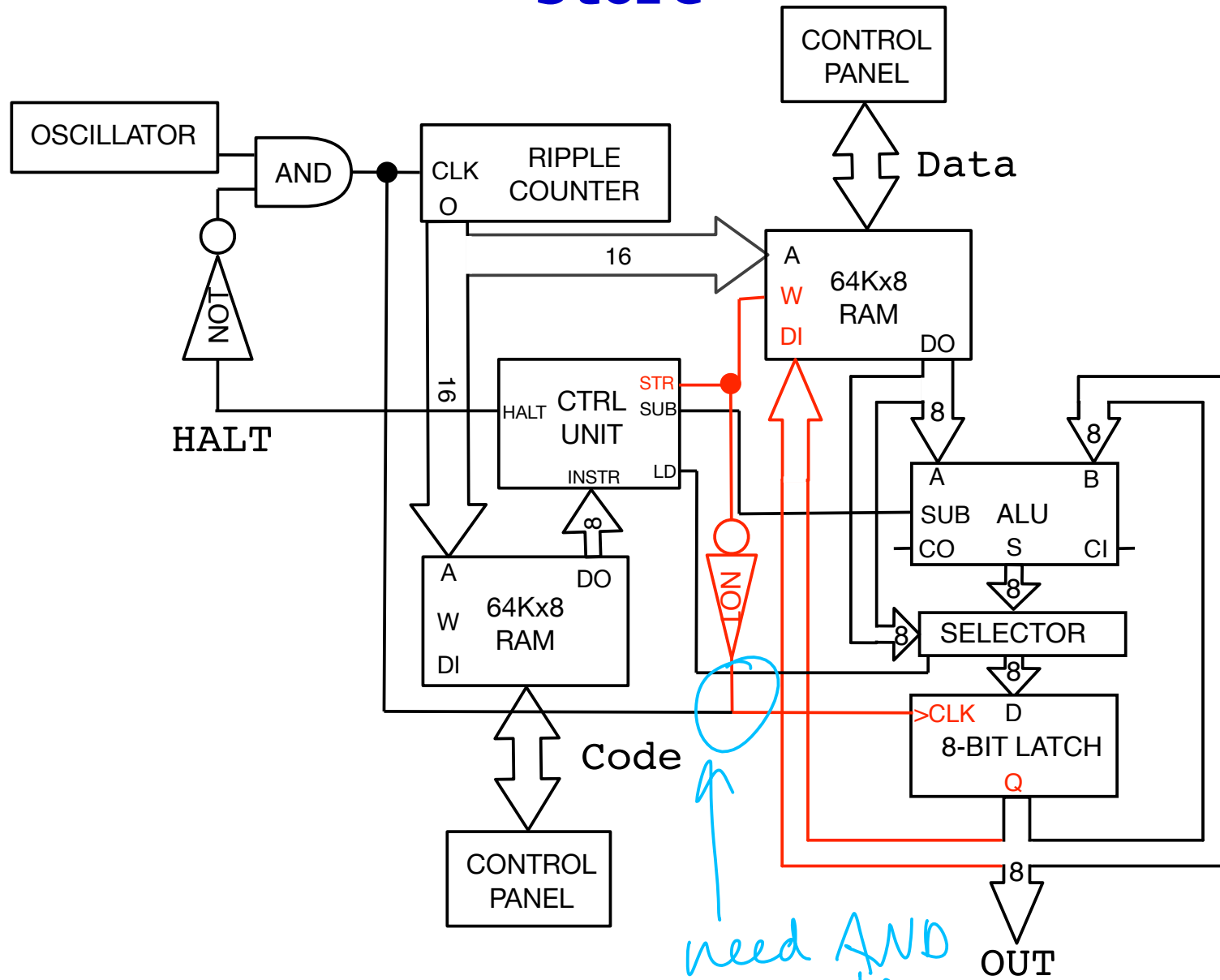

# Halt

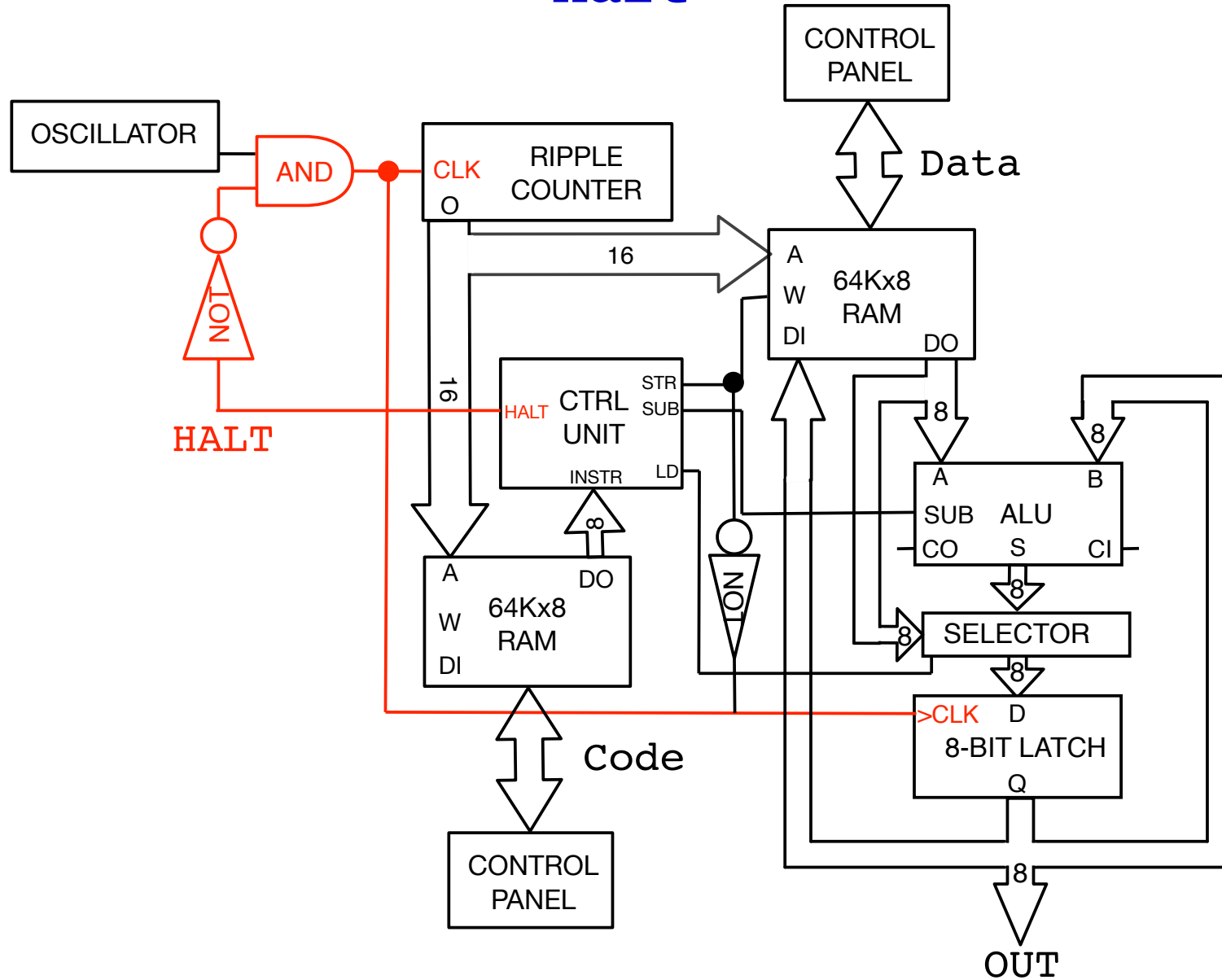

# Operations and Wiring

- Each operation changes certain flags

Operation	Code (hex)	LD	STR	SUB	HALT
Load	10h	1	0	0	0
Store	11h	0	1	0	0
Add	20h	0	0	0	0
Subtract	21h	0	0	1	0
Halt	FFh	0	0	0	1

# Program Example

Address	Code	Data	Accumulator
0000h	10h Load	56h	
0001h	20h Add	2Ah	
0002h	21h Subtract	38h	
0003h	11h Store		
0004h	FFh Halt		

# Program Example

Address	Code	Data	Accumulator
			00h
0000h	10h Load	56h	
0001h	20h Add	2Ah	
0002h	21h Subtract	38h	
0003h	11h Store		
0004h	FFh Halt		

# Program Example

Address	Code	Data	Accumulator
			00h
0000h	10h Load	56h	56h
0001h	20h Add	2Ah	
0002h	21h Subtract	38h	
0003h	11h Store		
0004h	FFh Halt		

# Program Example

Address	Code	Data	Accumulator
			00h
0000h	10h Load	56h	56h
0001h	20h Add	2Ah	80h
0002h	21h Subtract	38h	
0003h	11h Store		
0004h	FFh Halt		



# Program Example

Address	Code	Data	Accumulator
			00h
0000h	10h Load	56h	56h
0001h	20h Add	2Ah	80h
0002h	21h Subtract	38h	48h
0003h	11h Store		
0004h	FFh Halt		

# Program Example

Address	Code	Data	Accumulator
			00h
0000h	10h Load	56h	56h
0001h	20h Add	2Ah	80h
0002h	21h Subtract	38h	48h
0003h	11h Store		48h
0004h	FFh Halt		

# Program Example

Address	Code	Data	Accumulator
			00h
0000h	10h Load	56h	56h
0001h	20h Add	2Ah	80h
0002h	21h Subtract	38h	48h
0003h	11h Store		48h
0004h	FFh Halt		48h

# Program Example

Address	Code	Data	Accumulator
			00h
0000h	10h Load	56h	56h
0001h	20h Add	2Ah	80h
0002h	21h Subtract	38h	48h
0003h	11h Store		48h
0004h	FFh Halt		48h

# adding 16 bit numbers

# Adding 16 Bit Numbers



- 1 byte integers will not suffice in practice
  - unsigned: 0 to 255
  - signed: -128 to 127
- Let's use 2 bytes (16 bit)
- How can we do addition with our 8-bit adder?

# Adding 16 Bit Numbers



- 1 byte integers will not suffice in practice
  - unsigned: 0 to 255
  - signed: -128 to 127
- Let's use 2 bytes (16 bit)
- How can we do addition with our 8-bit adder?  
Add the bytes separately

# Example

- Task: 76ABh + 232Ch

- Lower order byte  
ABh  
+2Ch  
----  
D7h

- Higher order byte  
76h  
+23h  
----  
99h

- Putting it together: 99D7h



# Another Example

- Task: 76ABh + 236Ch

- Lower order byte  
ABh  
+6Ch  
----  
117h

- Higher order byte  
(add the carry)  
1h carry  
+76h  
+23h  
----  
9Ah

- Putting it together: 9AD7h

# More Instructions



- Add with Carry
  - when addition results in a carry, store this in a flag
  - new add instruction that includes carry if flag set

# More Instructions

- Add with Carry
  - when addition results in a carry, store this in a flag
  - new add instruction that includes carry if flag set
- Subtract with Borrow
  - when subtraction results in a carry, store this in a flag
  - new subtract instruction that includes carry if flag set

# Circuit

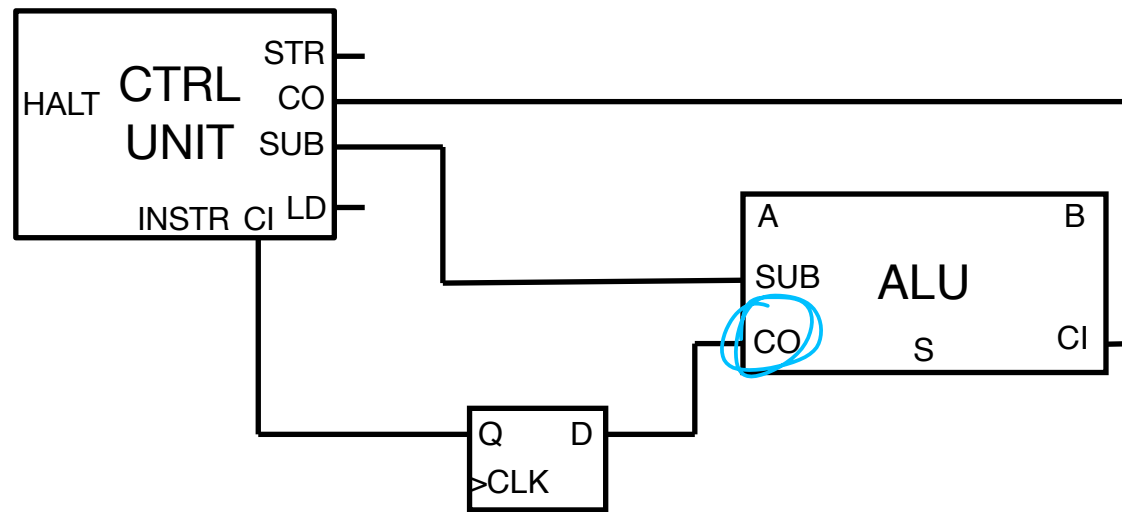

Carry  
Flag

# Instructions

- Each operation is encoded by a byte value

<b>Operation</b>	<b>Code (hex)</b>
Load	10h
Store	11h
Add	20h
Subtract	21h
Add with carry	22h
Subtract with borrow	23h
Halt	FFh

# Code



Address	Code	Data	Carry	Accumulator
0000h	10h Load	ABh		
0001h	20h Add	6Ch		
0002h	11h Store			
0003h	10h Load	76h		
0004h	22h Add with carry	23h		
0005h	11h Store			
0006h	FFh Halt			

# Code

Address	Code	Data	Carry	Accumulator
			0	00h
0000h	10h Load	ABh		
0001h	20h Add	6Ch		
0002h	11h Store			
0003h	10h Load	76h		
0004h	22h Add with carry	23h		
0005h	11h Store			
0006h	FFh Halt			

# Code

Address	Code	Data	Carry	Accumulator
			0	00h
0000h	10h Load	ABh	0	ABh
0001h	20h Add	6Ch		
0002h	11h Store			
0003h	10h Load	76h		
0004h	22h Add with carry	23h		
0005h	11h Store			
0006h	FFh Halt			



# Code

Address	Code	Data	Carry	Accumulator
			0	00h
0000h	10h Load	ABh	0	ABh
0001h	20h Add	6Ch	1	17h
0002h	11h Store			
0003h	10h Load	76h		
0004h	22h Add with carry	23h		
0005h	11h Store			
0006h	FFh Halt			

# Code

Address	Code	Data	Carry	Accumulator
			0	00h
0000h	10h Load	ABh	0	ABh
0001h	20h Add	6Ch	1	17h
0002h	11h Store		1	17h
0003h	10h Load	76h		
0004h	22h Add with carry	23h		
0005h	11h Store			
0006h	FFh Halt			

# Code

Address	Code	Data	Carry	Accumulator
			0	00h
0000h	10h Load	ABh	0	ABh
0001h	20h Add	6Ch	1	17h
0002h	11h Store		1	17h
0003h	10h Load	76h	1	76h
0004h	22h Add with carry	23h		
0005h	11h Store			
0006h	FFh Halt			

# Code

Address	Code	Data	Carry	Accumulator
			0	00h
0000h	10h Load	ABh	0	ABh
0001h	20h Add	6Ch	1	17h
0002h	11h Store		1	17h
0003h	10h Load	76h	1	76h
0004h	22h <u>Add with carry</u>	23h	0	9Ah
0005h	11h Store			
0006h	FFh Halt			

"condition codes"  
carry, borrow, etc.

# Code

Address	Code	Data	Carry	Accumulator
			0	00h
0000h	10h Load	ABh	0	ABh
0001h	20h Add	6Ch	1	17h
0002h	11h Store		1	17h
0003h	10h Load	76h	1	76h
0004h	22h Add with carry	23h	0	9Ah
0005h	11h Store		0	9Ah
0006h	FFh Halt			

# Code

Address	Code	Data	Carry	Accumulator
			0	00h
0000h	10h Load	ABh	0	ABh
0001h	20h Add	6Ch	1	17h
0002h	11h Store		1	17h
0003h	10h Load	76h	1	76h
0004h	22h Add with carry	23h	0	9Ah
0005h	11h Store		0	9Ah
0006h	FFh Halt		0	9Ah

# Code

Address	Code	Data	Carry	Accumulator
			0	00h
0000h	10h Load	ABh	0	ABh
0001h	20h Add	6Ch	1	17h
0002h	11h Store		1	17h
0003h	10h Load	76h	1	76h
0004h	22h Add with carry	23h	0	9Ah
0005h	11h Store		0	9Ah
0006h	FFh Halt		0	9Ah



# addressing memory



# Motivation



- Currently using two memories
  - code memory for instructions
  - data memory
- Very limiting
- Instead:
  - store code and data in same memory
  - add explicit addresses to instructions

# Adapted 16-Bit Adder

- Memory

Address	Data
4000h	ABh
4001h	76h
4002h	6Ch
4003h	23h

} loc. of data in memory

- Code

Address	Bytes	Code
0000h	10h 00h 40h	Load 4000h
0003h	20h 02h 40h	Add 4002h
0006h	11h 04h 40h	Store 4004h
0009h	10h 01h 40h	Load 4001h
000Ch	22h 03h 40h	Add with carry 4003h
000Fh	11h 05h 40h	Store 4005h
0012h	FFh	Halt

data address

# Adapted 16-Bit Adder

- Memory

Address	Data
4000h	ABh
4001h	76h
4002h	6Ch
4003h	23h

- Code

Note:  
Instructions  
take up  
1 or 3 bytes

Address	Bytes	Code
0000h	10h 00h 40h	Load 4000h
0003h	20h 02h 40h	Add 4002h
0006h	11h 04h 40h	Store 4004h
0009h	10h 01h 40h	Load 4001h
000Ch	22h 03h 40h	Add with carry 4003h
000Fh	11h 05h 40h	Store 4005h
0012h	FFh	Halt

# Instruction Fetch

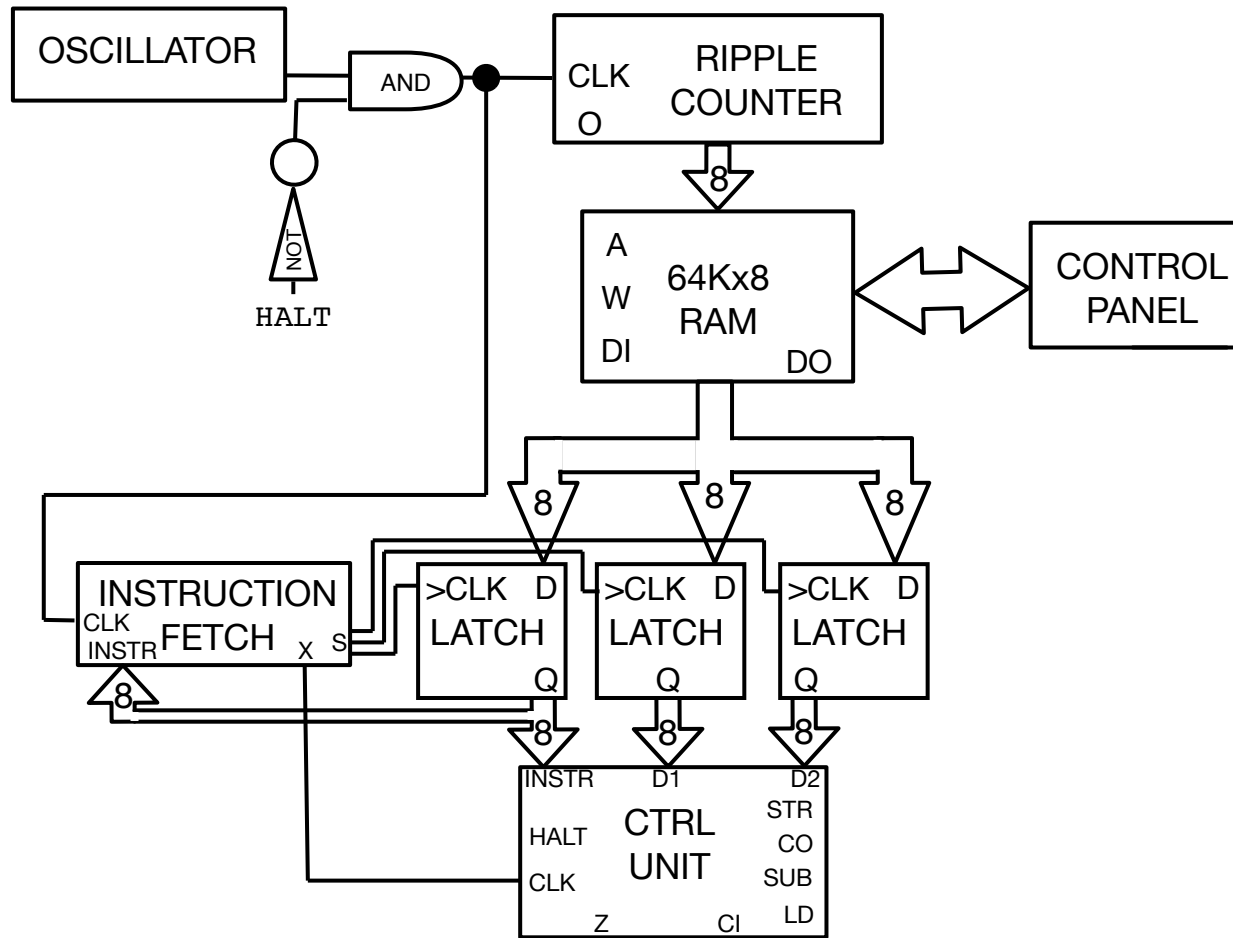

3 registers: code and 2 byte data

# Instruction Fetch

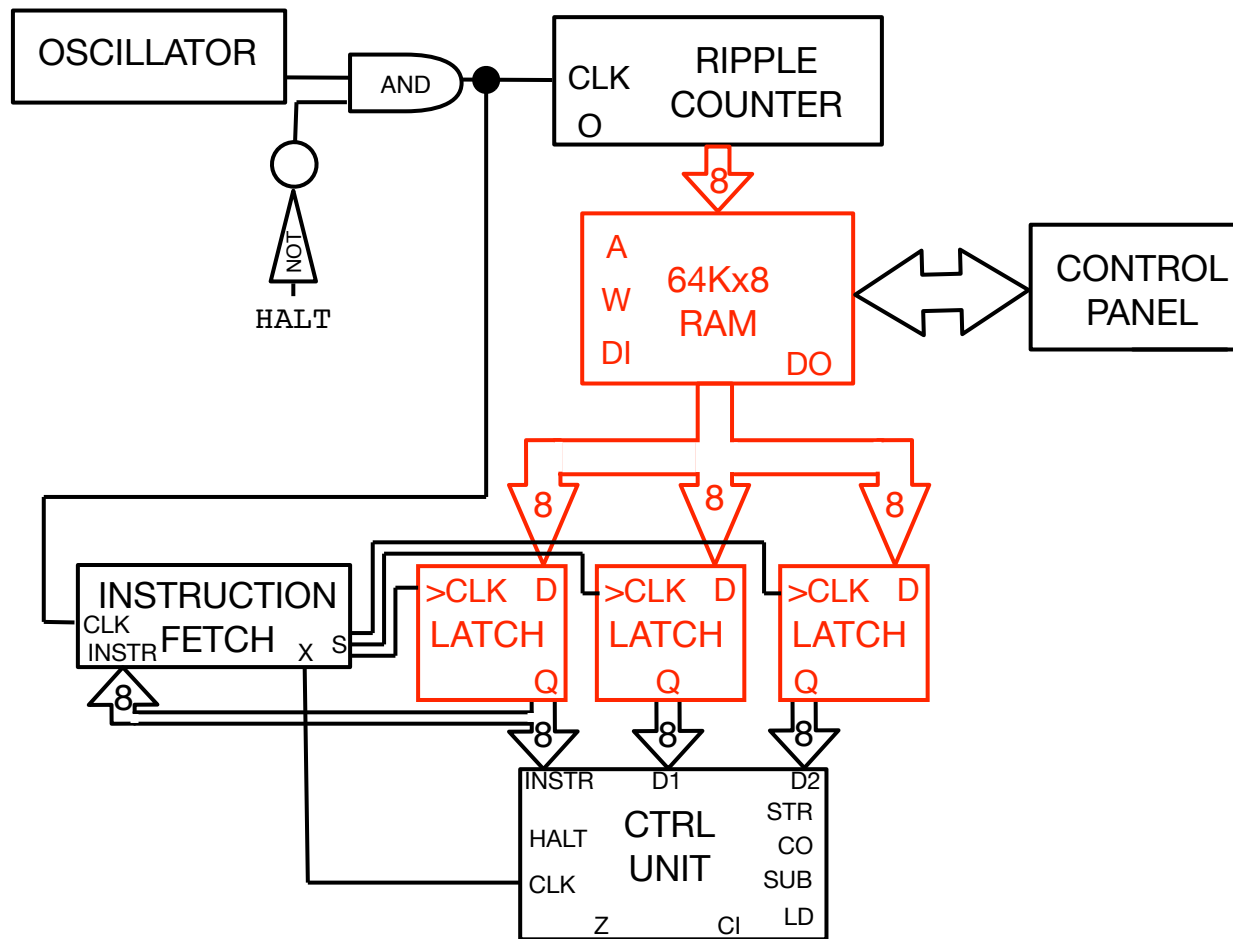

Transfer bytes from memory to instruction code and data register

# Instruction Fetch

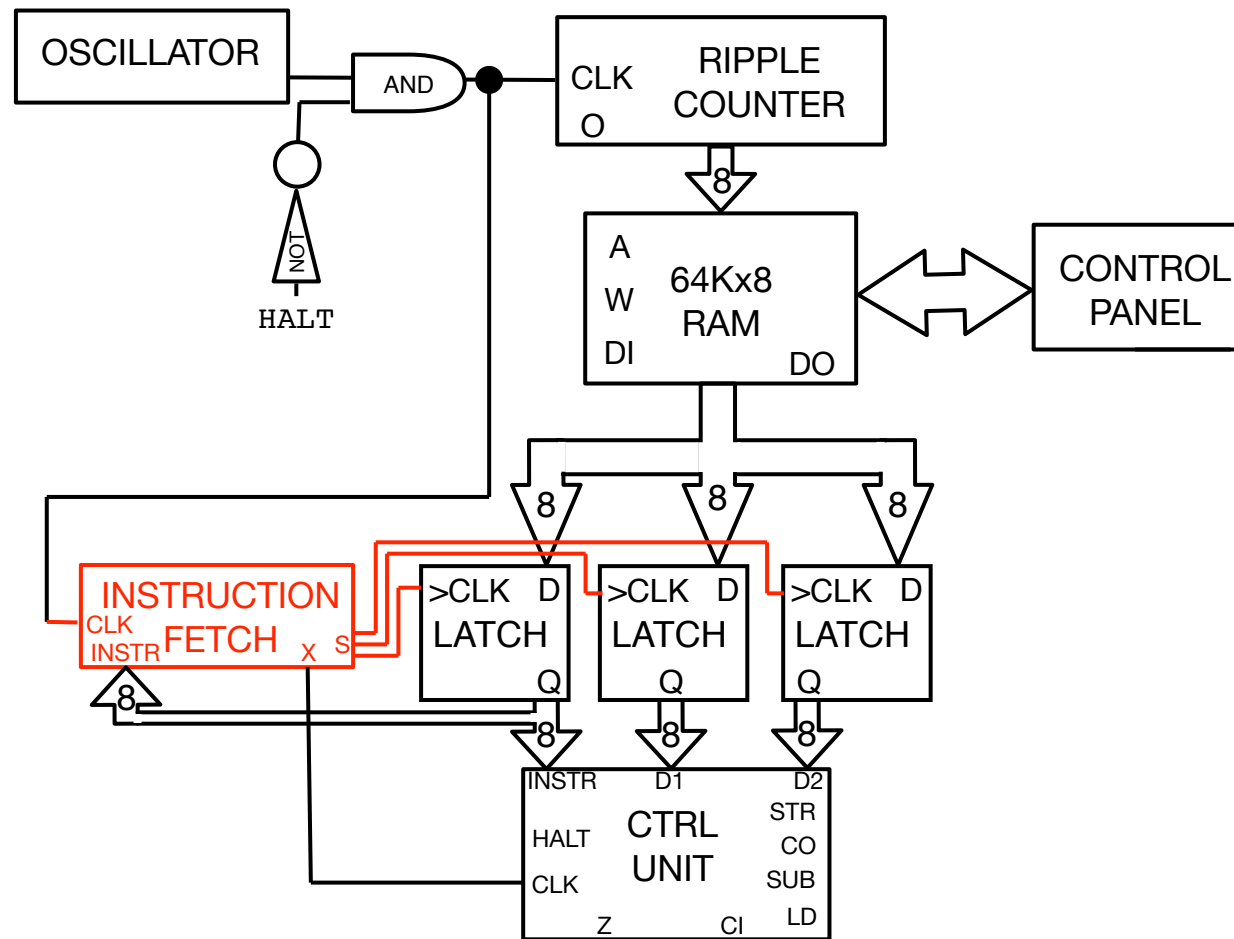

Instruction fetch logic determines which register is written to

# Instruction Fetch

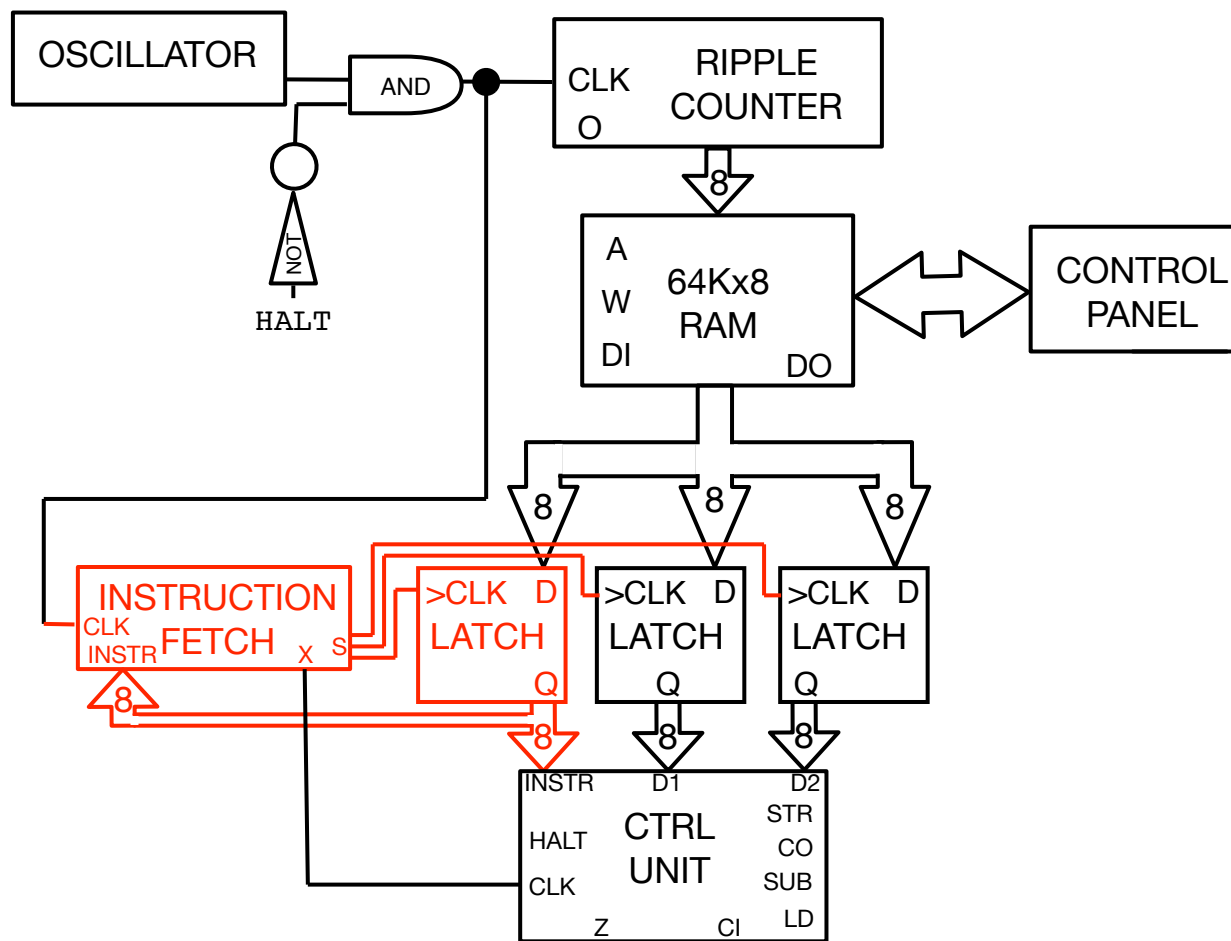

This is informed by instruction code

# Instruction Fetch

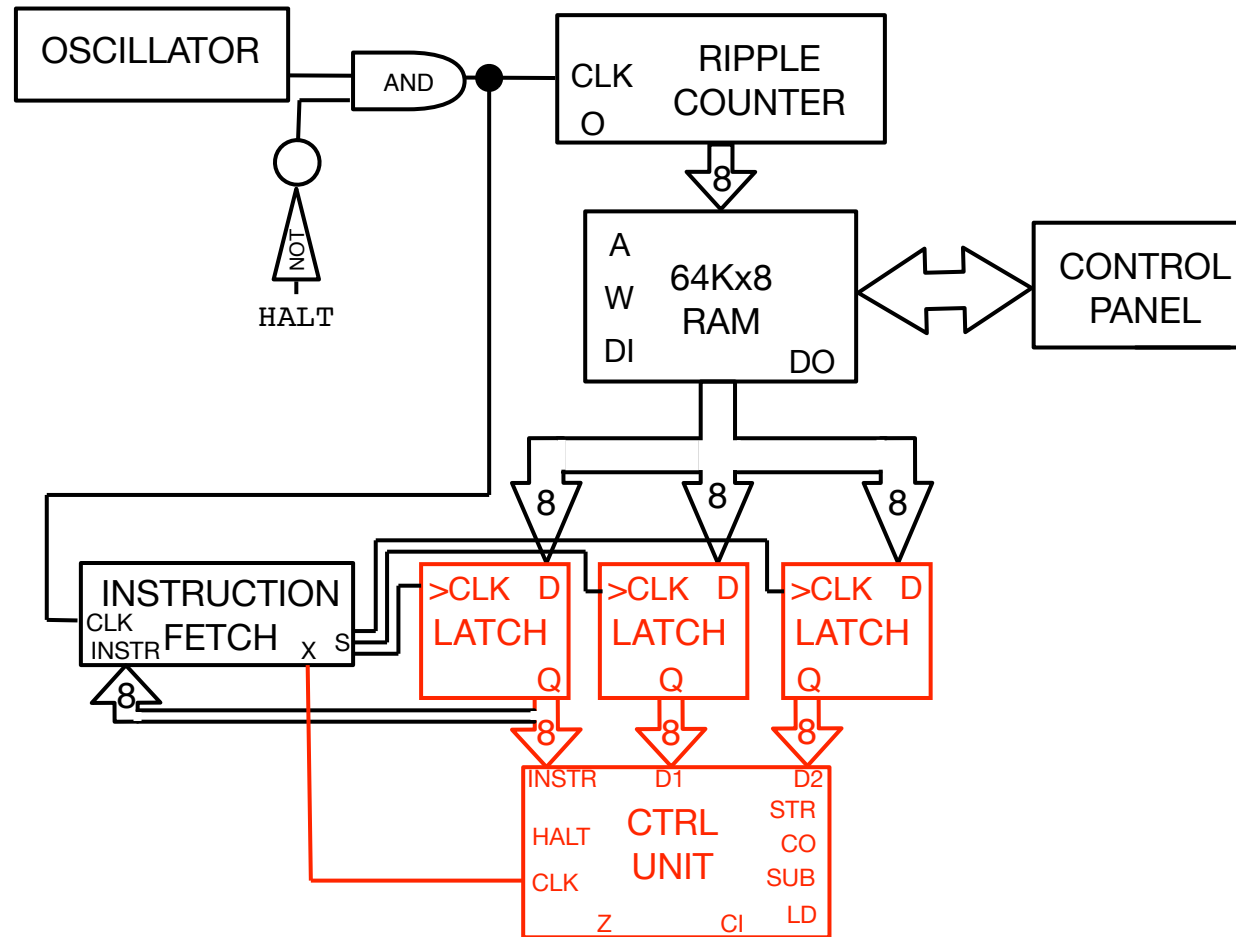

Once all registers are filled, execute instruction



# Data Paths



- Data needs to be transferred in various ways
- Address passed on to memory (overriding program counter)
- Add/subtract: read byte from memory, pass to ALU
- Load: read byte from memory, store in accumulator
- Store: read byte from accumulator, store in memory
- No detailed wiring worked out here...



# multiplication

# Plan

- Multiplication by repeated addition

- Pseudo-code

```
load number1 into accumulator
loop
  subtract 1 from number2
  last if number2 = 0
  add number1 to accumulator
store accumulator in result
```

# Needed



- Jump
  - set the ripple counter to specified value

# Needed

- Jump
  - set the ripple counter to specified value
- Zero flag
  - detect that subtraction resulted in number 0
  - implemented as flag of the ALU

# Needed



- Jump
  - set the ripple counter to specified value
- Zero flag
  - detect that subtraction resulted in number 0
  - implemented as flag of the ALU
- Jump if zero
  - check if zero flag is set
  - only then update ripple counter
  - otherwise, do nothing

# Zero Flag

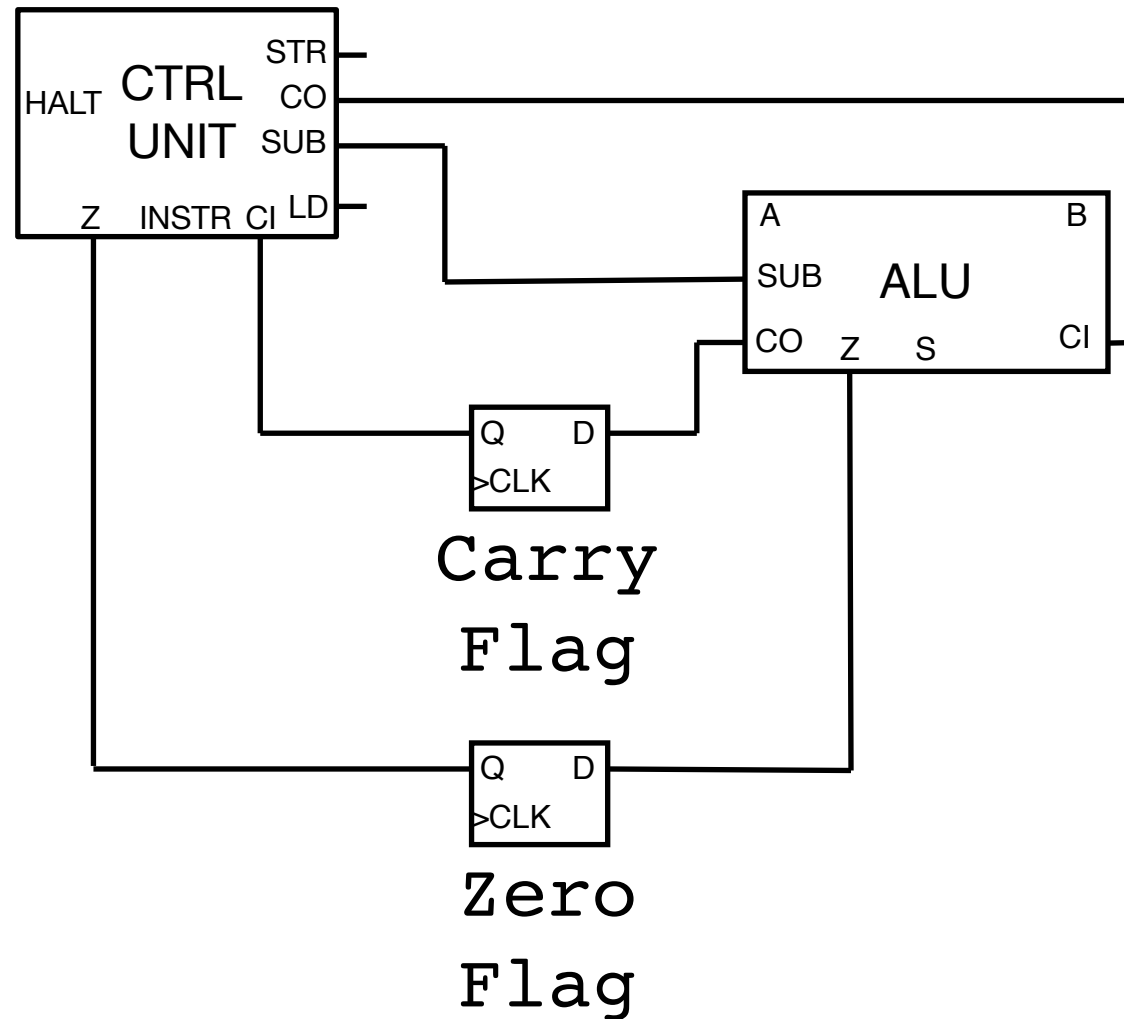

- Flag when the ALU operation results in 0

# Instructions

Operation	Code (hex)
Load	10h
Store	11h
Add	20h
Subtract	21h
Add with carry	22h
Subtract with borrow	23h
Jump	30h
Jump if zero	31h
Jump if carry	32h
Jump if not zero	33h
Jump if not carry	34h
Halt	FFh



# Code (8 Bit Version)

- Memory

Address	Data
4000h	0Bh
4001h	0Fh
4002h	01h

- Code

Address	Bytes	Code
0000h	10h 00h 40h	Load 4000h ; load number1
0003h	11h 03h 40h	Store 4003h ; save in result
0006h	10h 01h 40h	Load 4001h ; load number2
0009h	21h 02h 40h	Subtract 4002h ; subtract 1
000Bh	31h 18h 00h	jump if zero to 0018h ; jump to end if done
000Fh	10h 03h 40h	load 4003h ; load result
0012h	20h 00h 40h	add 4000h ; add number1
0015h	30h 03h 00h	jump to 0003h ; loop
0018h	FFh	halt ; quit