

# Lecture 13: Pipelining

Philipp Koehn

February 27, 2023

601.229 Computer Systems Fundamentals



# MIPS overview



- ▶ Developed by MIPS Technologies in 1984, first product in 1986
- ▶ Used in
  - ▶ Silicon Graphics (SGI) Unix workstations
  - ▶ Digital Equipment Corporation (DEC) Unix workstation
  - ▶ Nintendo 64
  - ▶ Sony PlayStation
- ▶ Inspiration for ARM (esp. v8)

# Overview

- ▶ 32 bit architecture (registers, memory addresses)
- ▶ 32 registers
- ▶ Multiply and divide instructions
- ▶ Floating point numbers

# Example: Addition

- ▶ Mathematical view of addition

$$a = b + c$$

# Example: Addition

- ▶ Mathematical view of addition

$$a = b + c$$

- ▶ MIPS instruction

add a,b,c

a, b, c are registers

# 32 Registers

- ▶ Some are special
  - 0 \$zero always has the value 0
  - 31 \$ra contains return address

## 32 Registers

- ▶ Some are special
  - 0 `$zero` always has the value 0
  - 31 `$ra` contains return address
- ▶ Some have usage conventions
  - 1 `$at` reserved for pseudo-instructions



## 32 Registers

- ▶ Some are special
  - 0 \$zero always has the value 0
  - 31 \$ra contains return address
- ▶ Some have usage conventions
  - 1 \$at reserved for pseudo-instructions
  - 2-3 \$v0-\$v1 return values of a function call
  - 4-7 \$a0-\$a3 arguments for a function call

## 32 Registers

- ▶ Some are special
  - 0 \$zero always has the value 0
  - 31 \$ra contains return address
- ▶ Some have usage conventions
  - 1 \$at reserved for pseudo-instructions
  - 2-3 \$v0-\$v1 return values of a function call
  - 4-7 \$a0-\$a3 arguments for a function call
  - 8-15,24,25 \$t0-\$t9 temporaries, can be overwritten by function
  - 16-23 \$s0-\$s7 saved, have to be preserved by function

## 32 Registers

- ▶ Some are special
  - 0 \$zero always has the value 0
  - 31 \$ra contains return address
- ▶ Some have usage conventions
  - 1 \$at reserved for pseudo-instructions
  - 2-3 \$v0-\$v1 return values of a function call
  - 4-7 \$a0-\$a3 arguments for a function call
  - 8-15,24,25 \$t0-\$t9 temporaries, can be overwritten by function
  - 16-23 \$s0-\$s7 saved, have to be preserved by function
  - 26-27 \$k0-\$k1 reserved for kernel
  - 28 \$gp global area pointer
  - 29 \$sp stack pointer
  - 30 \$fp frame pointer

# Pipelining

# Laundry Analogy

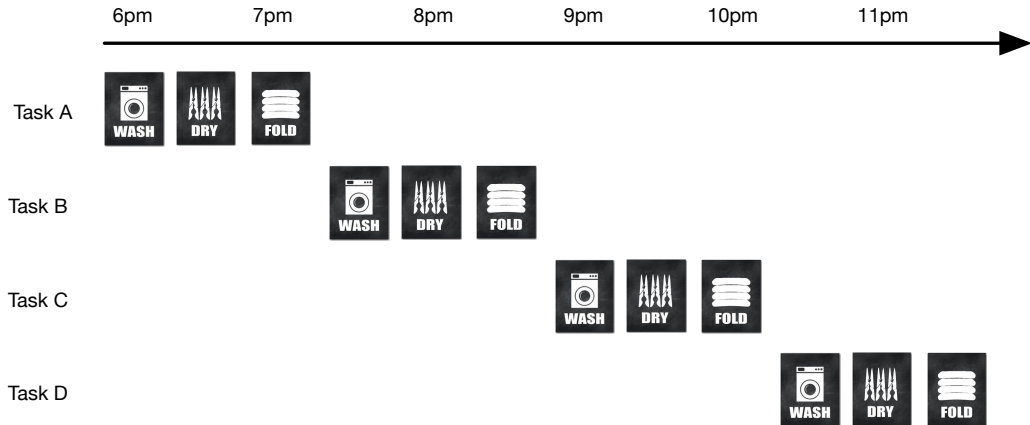

# Laundry Pipelined

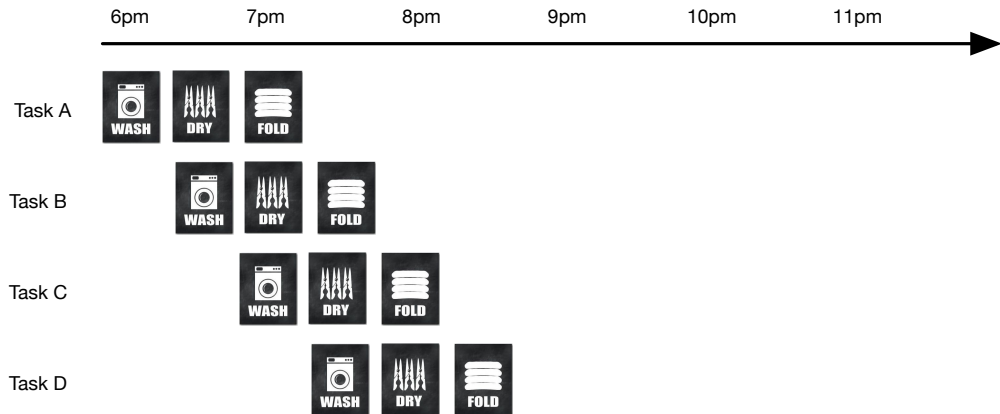

# Speed-up

- ▶ Theoretical speed-up: 3 times
- ▶ Actual speed-up in example: 2 times
  - ▶ sequential:  $1:30+1:30+1:30+1:30 = 6$  hours
  - ▶ pipelined:  $1:30+0:30+0:30+0:30 = 3$  hours
- ▶ Many tasks  $\rightarrow$  speed-up approaches theoretical limit

# MIPS instruction pipeline



# MIPS Pipeline

- ▶ Fetch instruction from memory
- ▶ Read registers and decode instruction (note: registers are always encoded in same place in instruction)
- ▶ Execute operation OR calculate an address
- ▶ Access an operand in memory
- ▶ Write result into a register

# Time for Instructions

Breakdown for each type of instruction

<b>Instruction class</b>	<b>Instr. fetch</b>	<b>Register read</b>	<b>ALU oper.</b>	<b>Data access</b>	<b>Register write</b>	<b>Total time</b>
Load word (lw)	200ps	100ps	200ps	200ps	100ps	800ps
Store word (sw)	200ps	100ps	200ps	200ps		700ps
R-format (add)	200ps	100ps	200ps		100ps	600ps
Branch (beq)	200ps	100ps	200ps			500ps

# Pipeline Execution

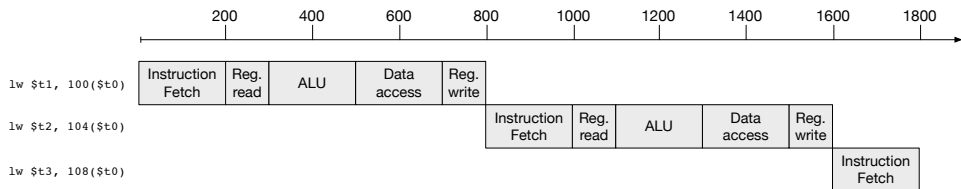

# Pipeline Execution

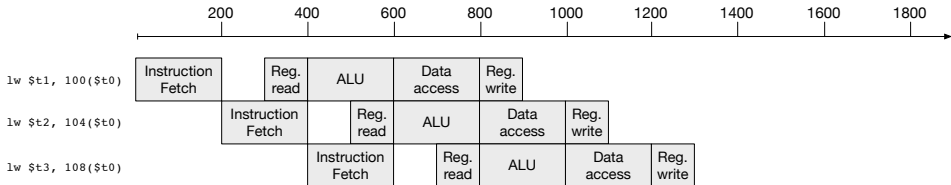
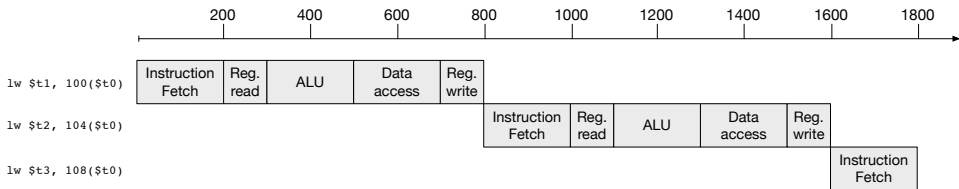

# Speed-up

- ▶ Theoretical speed-up: 4 times
- ▶ Actual speed-up in example: 1.71 times
  - ▶ sequential:  $800\text{ps} + 800\text{ps} + 800\text{ps} = 2400\text{ps}$
  - ▶ pipelined:  $1000\text{ps} + 200\text{ps} + 200\text{ps} = 1400\text{ps}$
- ▶ Many tasks  $\rightarrow$  speed-up approaches theoretical limit

# Design for Pipelining

- ▶ All instructions are 4 bytes  
→ easy to fetch next instruction

# Design for Pipelining

- ▶ All instructions are 4 bytes  
→ easy to fetch next instruction
- ▶ Few instruction formats  
→ parallel op decode and register read

# Design for Pipelining

- ▶ All instructions are 4 bytes  
→ easy to fetch next instruction
- ▶ Few instruction formats  
→ parallel op decode and register read
- ▶ Memory access limited to load and store instructions  
→ stage 3 used for memory access, otherwise operation execution



# Design for Pipelining

- ▶ All instructions are 4 bytes  
→ easy to fetch next instruction
- ▶ Few instruction formats  
→ parallel op decode and register read
- ▶ Memory access limited to load and store instructions  
→ stage 3 used for memory access, otherwise operation execution
- ▶ Words aligned in memory  
→ able to read in one instruction  
(aligned = memory address multiple of 4)

# Hazards

# Hazards

- ▶ Hazard = next instruction cannot be executed in next clock cycle
- ▶ Types
  - ▶ structural hazard
  - ▶ data hazard
  - ▶ control hazard

# Structural Hazard

- ▶ Definition: instructions overlap in resource use in same stage
- ▶ For instance: memory access conflict

	1	2	3	4	5	6	7
i1	FETCH	DECODE	MEMORY	MEMORY	ALU	REGISTER	
i2		FETCH	DECODE	MEMORY	MEMORY	ALU	REGISTER

conflict

- ▶ MIPS designed to avoid structural hazards

# Data Hazard

- ▶ Definition: instruction waits on result from prior instruction

- ▶ Example

  - add \$s0, \$t0, \$t1

  - sub \$t0, \$s0, \$t3

  - ▶ add instruction writes result to register \$s0 in stage 5

  - ▶ sub instruction reads \$s0 in stage 2

⇒ Stage 2 of sub has to be delayed

- ▶ We overcome this in hardware

# Graphical Representation

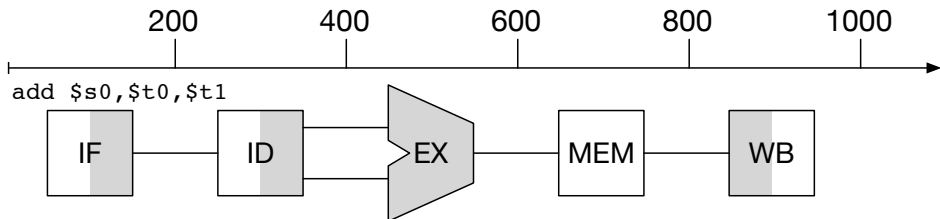

- ▶ IF: instruction fetch
- ▶ ID: instruction decode
- ▶ EX: execution
- ▶ MEM: memory access
- ▶ WB: write-back

# Add and Subtract

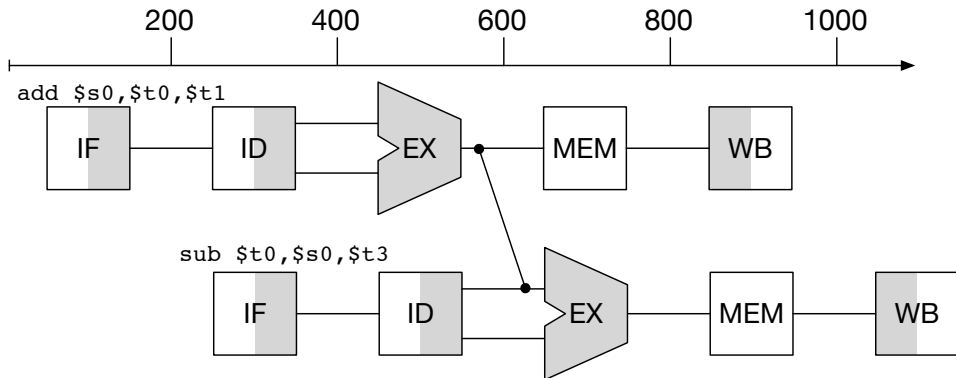

- ▶ Add wiring to circuit to directly connect output of ALU for next instruction

# Load and Subtract

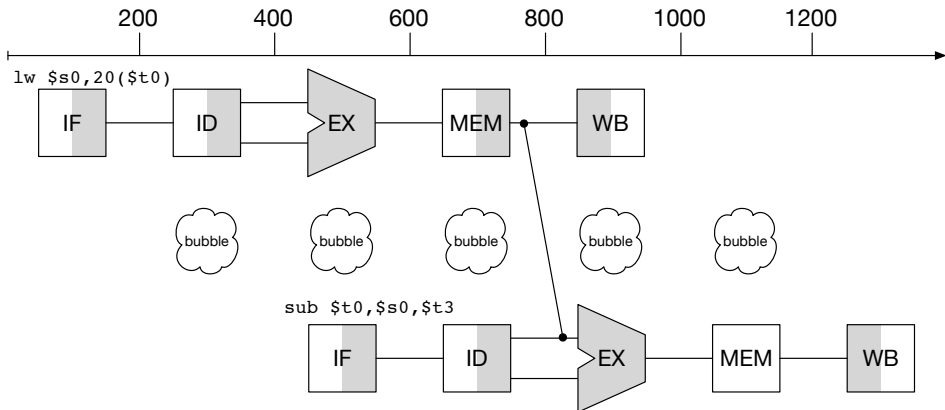

- ▶ Add wiring from memory lookup to ALU
- ▶ Still 1 cycle unused: "pipeline stall" or "bubble"



# Reorder Code

Code with data hazard

```
lw $t1, 0($t0)
lw $t2, 4($t0)
add $t3, $t1, $t2
sw $t3, 12($t0)
lw $t4, 8($t0)
add $t5, $t1, $t4
sw $t5, 16($t0)
```

# Reorder Code

Code with data hazard

```
lw $t1, 0($t0)
lw $t2, 4($t0)
add $t3, $t1, $t2
sw $t3, 12($t0)
lw $t4, 8($t0)
add $t5, $t1, $t4
sw $t5, 16($t0)
```

Reorder code (may be done by compiler)

# Reorder Code

Code with data hazard

```
lw $t1, 0($t0)
lw $t2, 4($t0)
add $t3, $t1, $t2
sw $t3, 12($t0)
lw $t4, 8($t0)
add $t5, $t1, $t4
sw $t5, 16($t0)
```

Reorder code (may be done by compiler)

```
lw $t1, 0($t0)
lw $t2, 4($t0)
lw $t4, 8($t0)
add $t3, $t1, $t2
sw $t3, 12($t0)
add $t5, $t1, $t4
sw $t5, 16($t0)
```

Load instruction now completed in time

# Clicker quiz!

Clicker quiz omitted from public slides

# Clicker quiz!

Clicker quiz omitted from public slides

# Control Hazard

- ▶ Also called branch hazard
- ▶ Selection of next instruction depends on outcome of previous
- ▶ Example

```
add $s0, $t0, $t1  
beq $s0, $s1, ff40  
sub $t0, $s0, $t3
```

- ▶ sub instruction only executed if branch condition fails  
→ cannot start until branch condition result known

# Branch Prediction

- ▶ Assume that branches are never taken  
→ full speed if correct
- ▶ More sophisticated
  - ▶ keep record of branch taken or not
  - ▶ make prediction based on history

# Pipelined data path



# Datapath

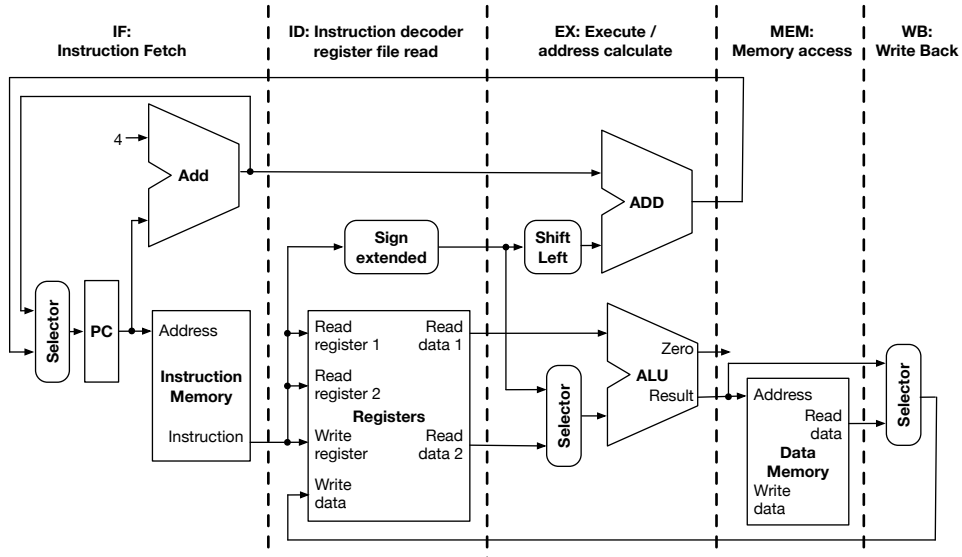

# Pipelined Datapath

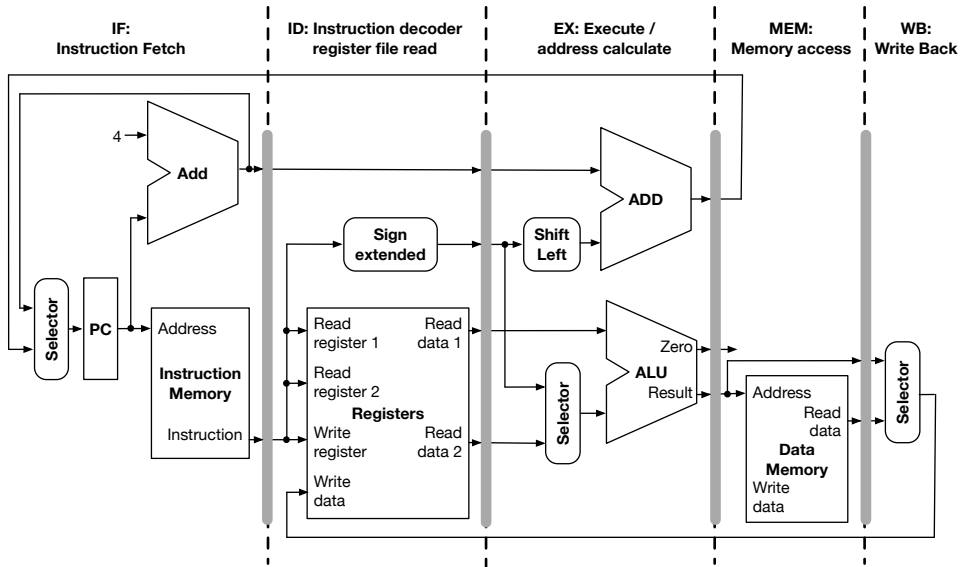

Load

# Load: Stage 1

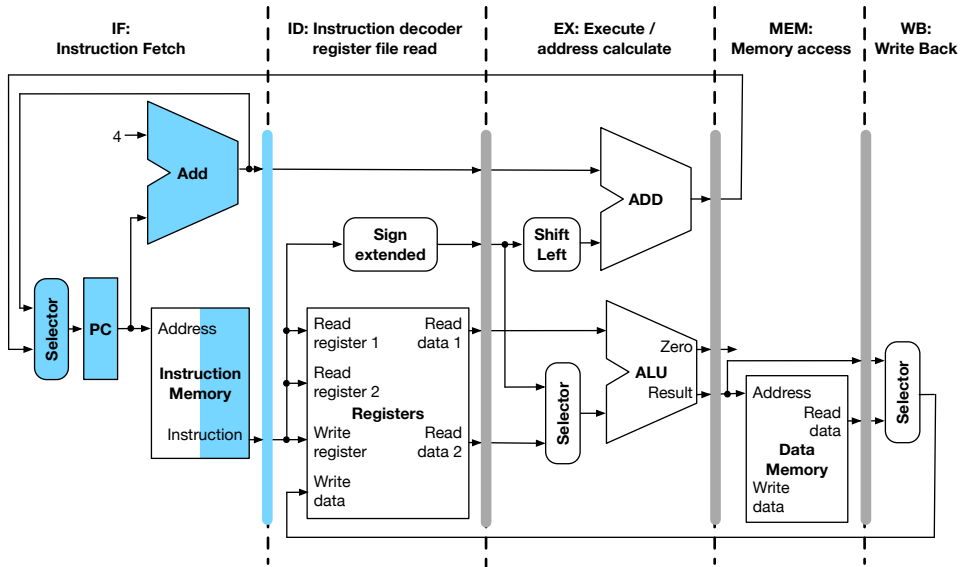

# Load: Stage 2

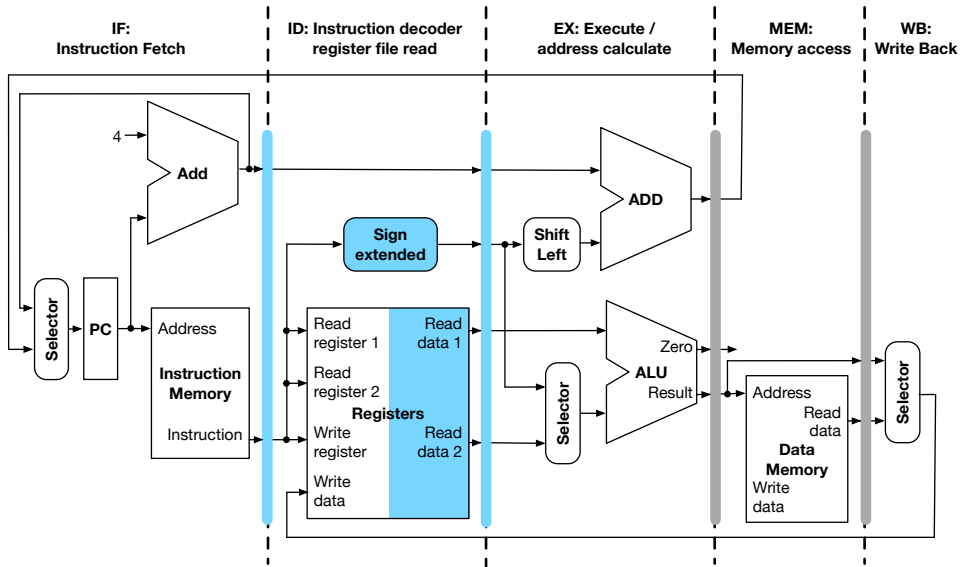

# Load: Stage 3

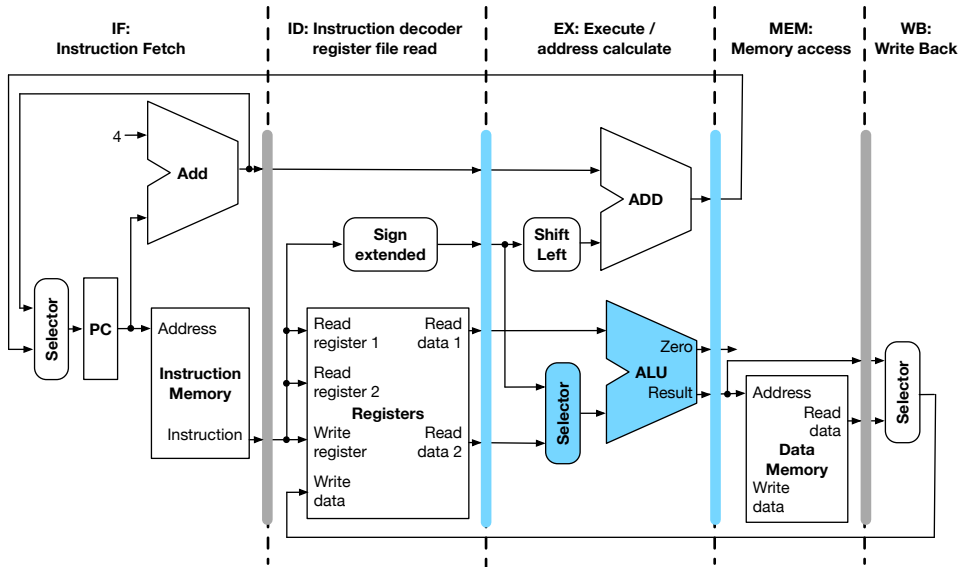

# Load: Stage 4

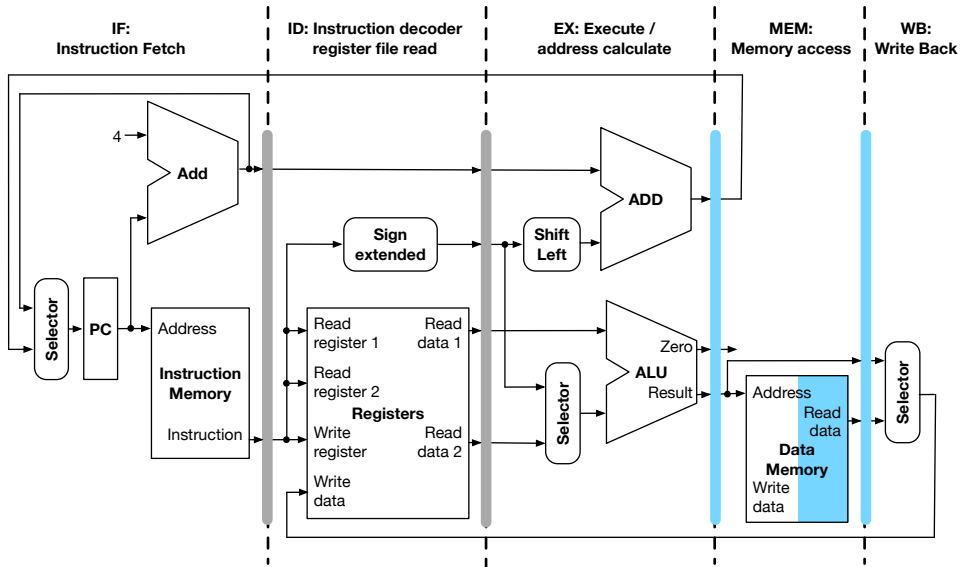

# Load: Stage 5

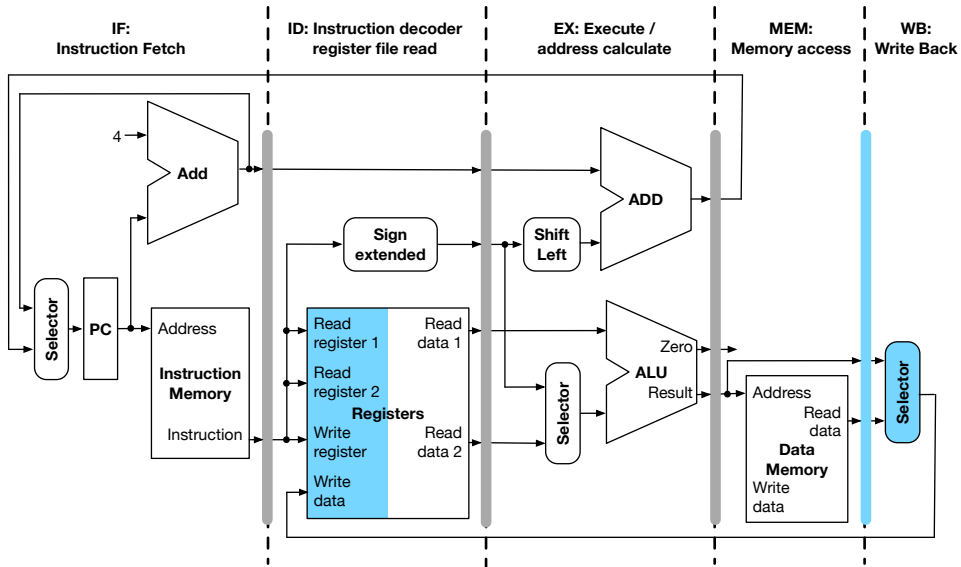



# Store

# Store: Stage 1

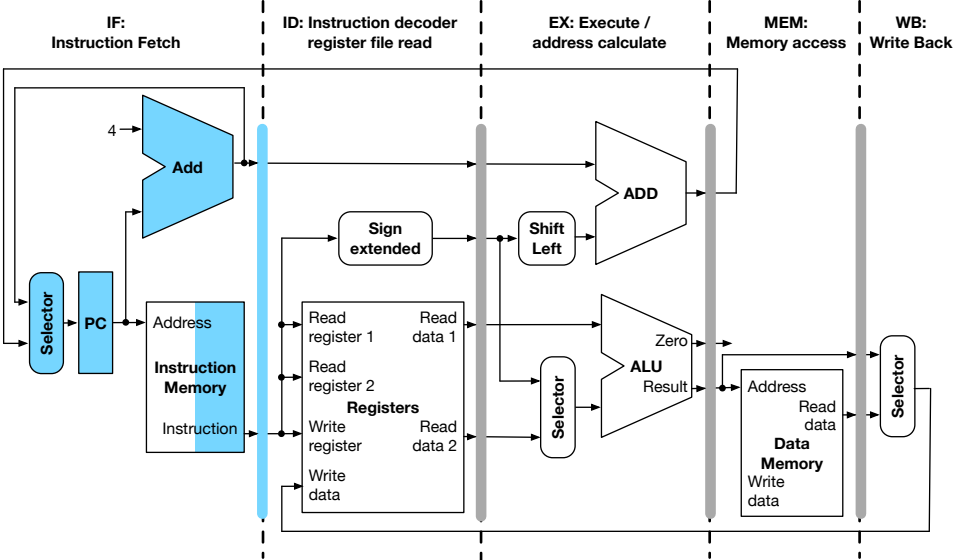

# Store: Stage 2

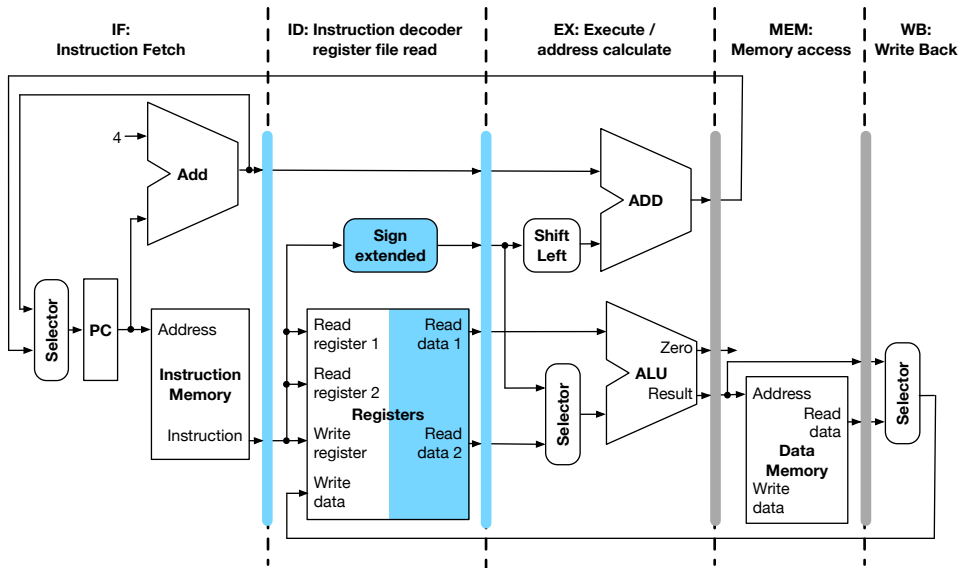

# Store: Stage 3

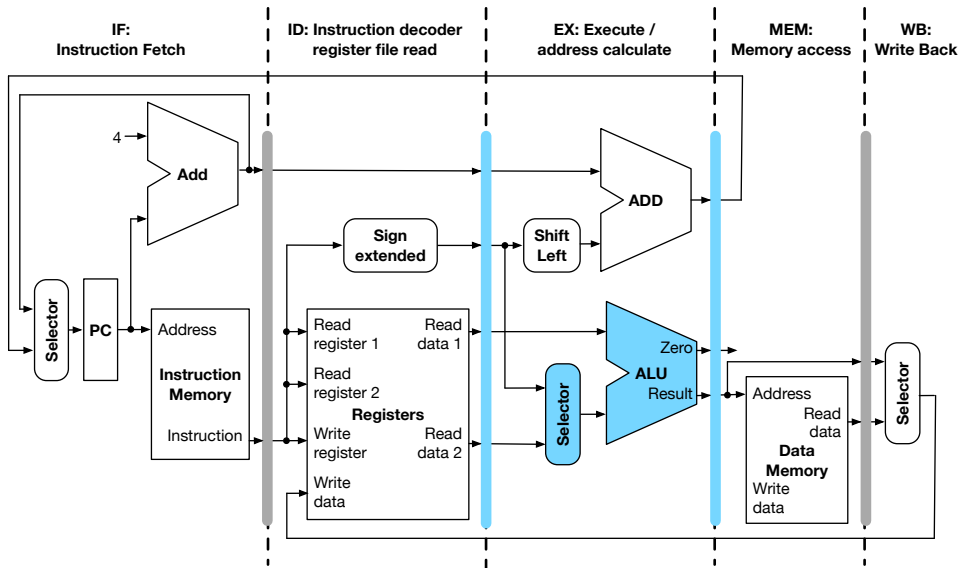

# Store: Stage 4

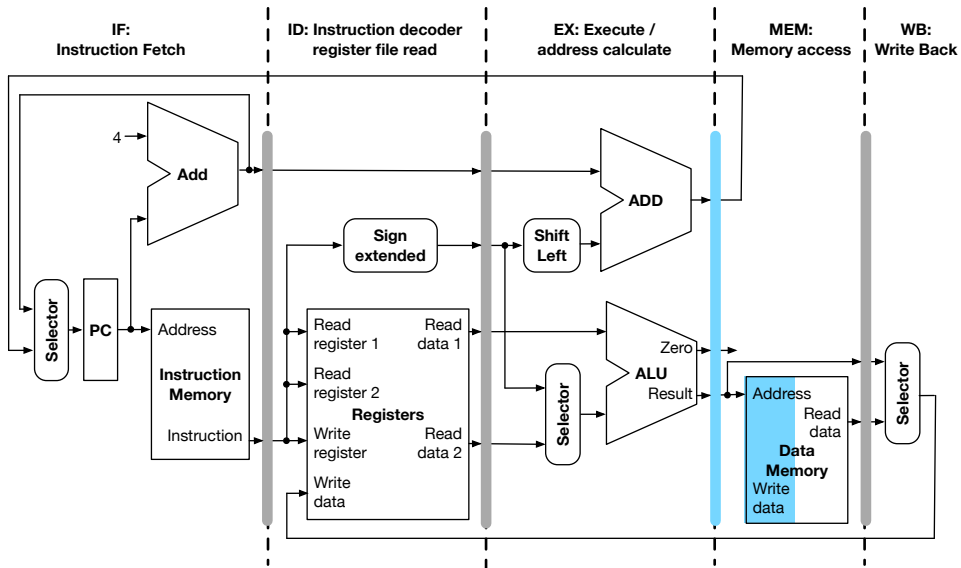

# Store: Stage 5

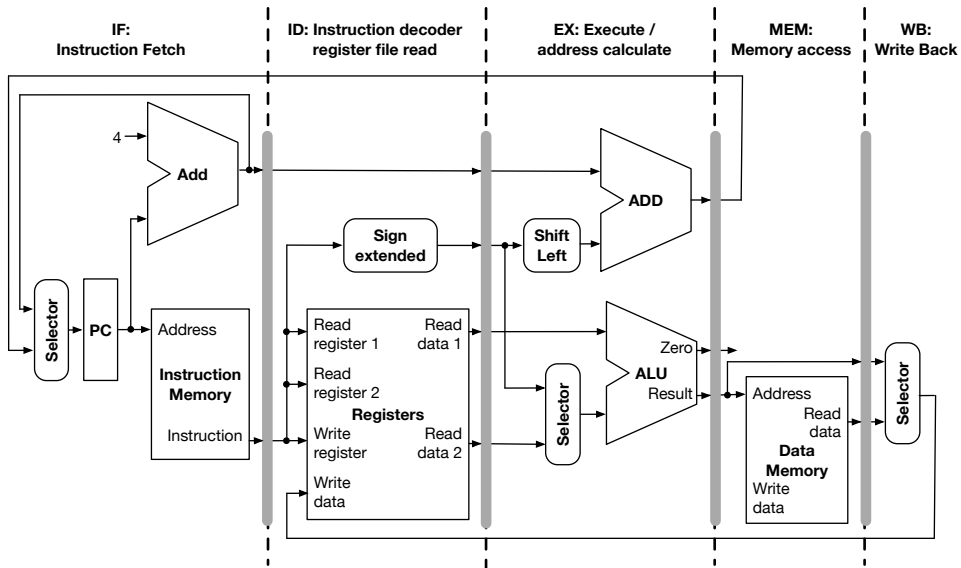

Add

# Add: Stage 1

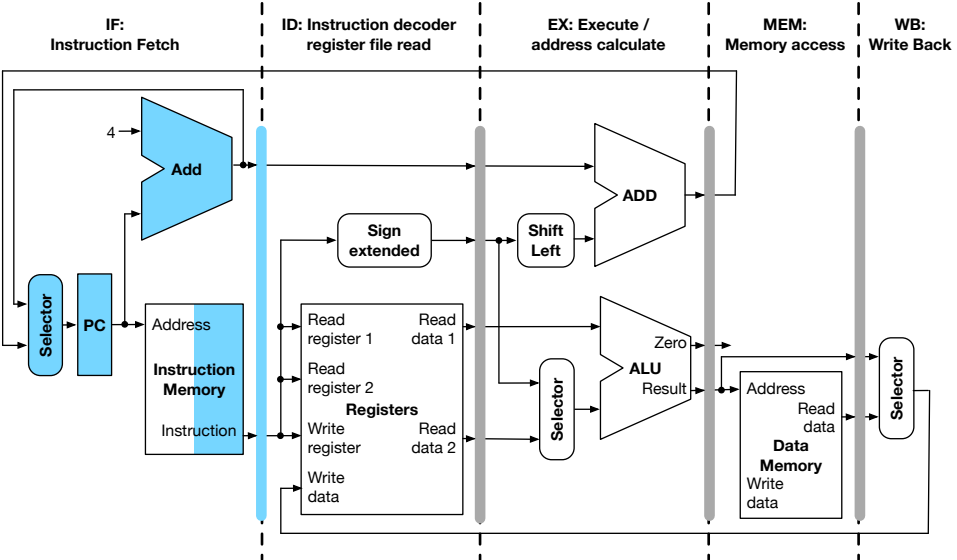



# Add: Stage 2

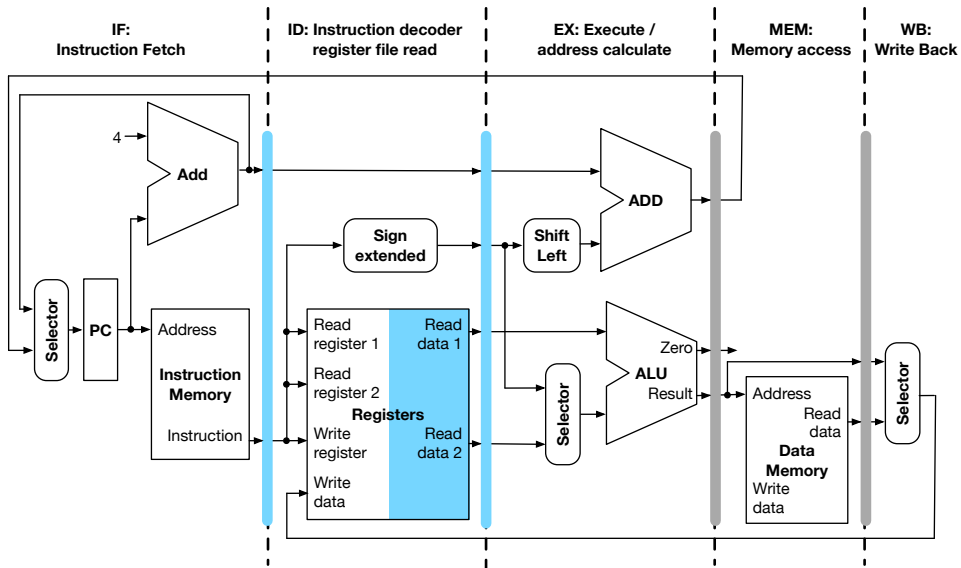

# Add: Stage 3

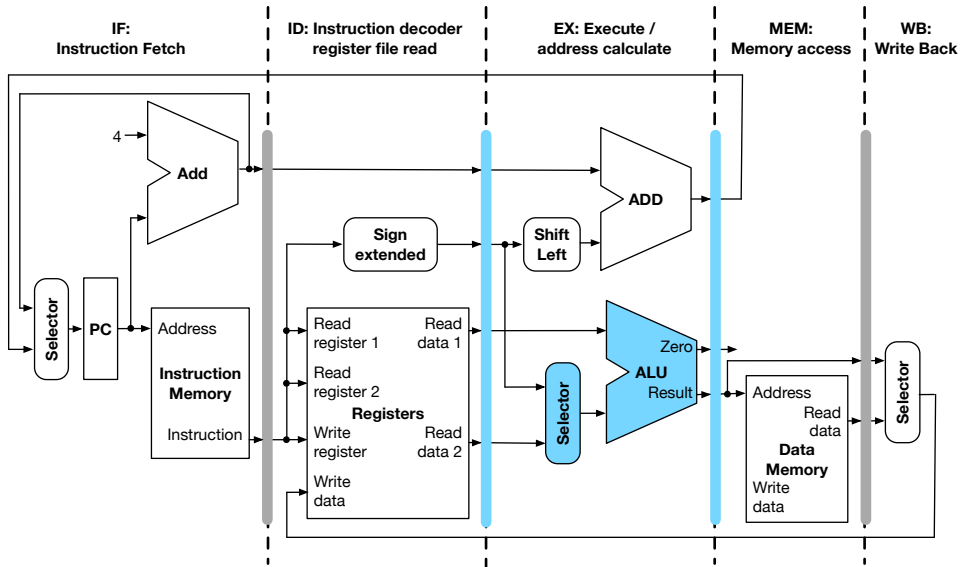

# Add: Stage 4

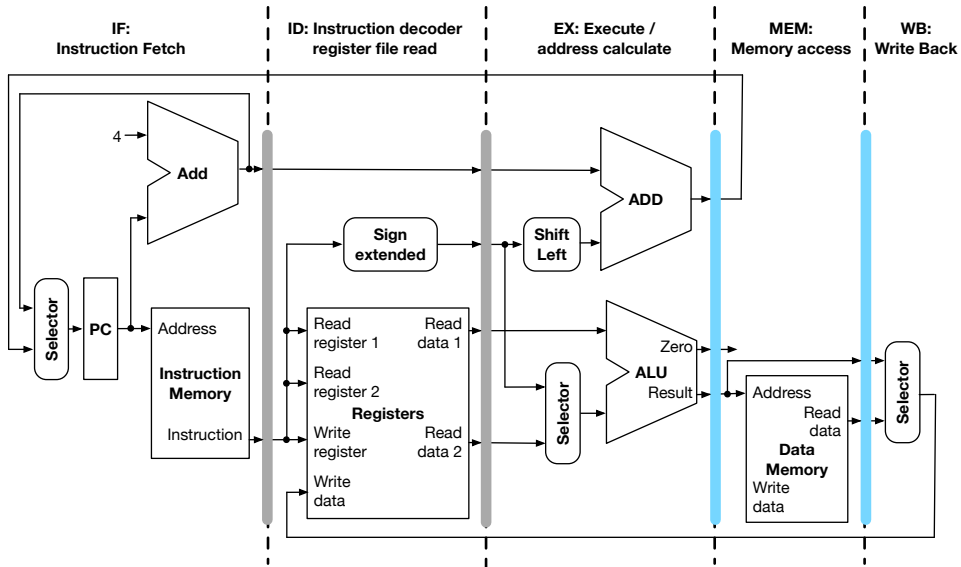

# Add: Stage 5

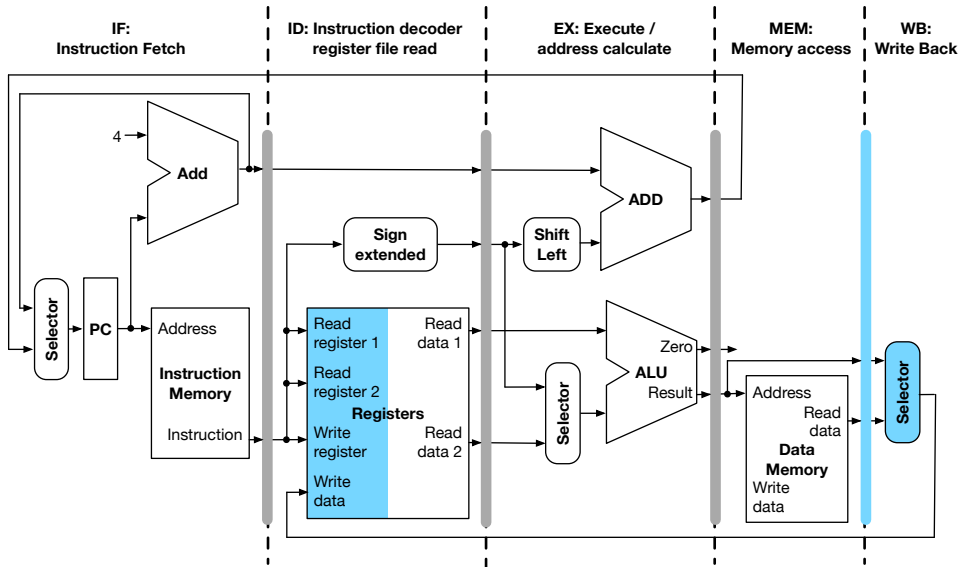

Write to register

# Which Register?

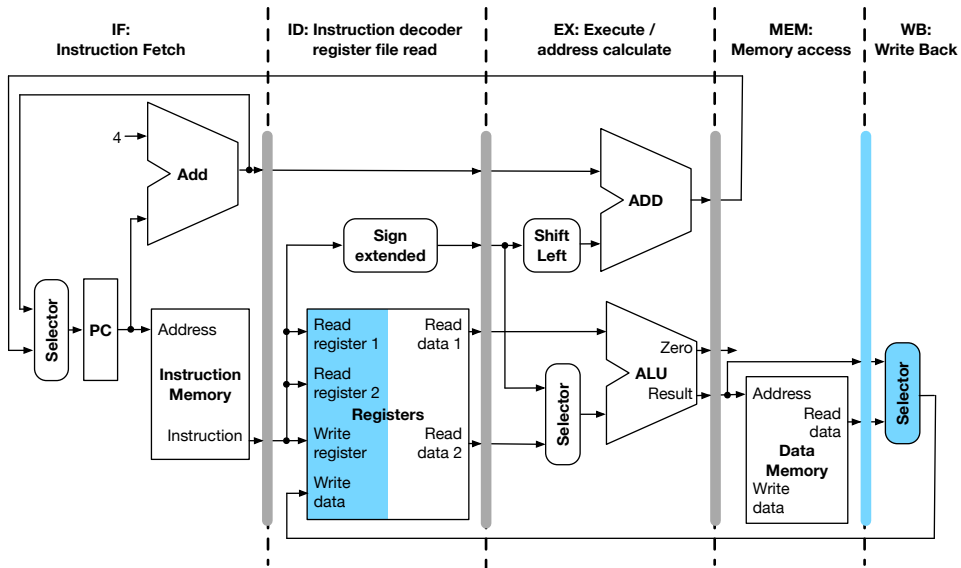

# Problem

- ▶ Write register
  - ▶ decoded in stage 2
  - ▶ used in stage 5
- ▶ Identity of register has to be passed along

# Data Path for Write Register

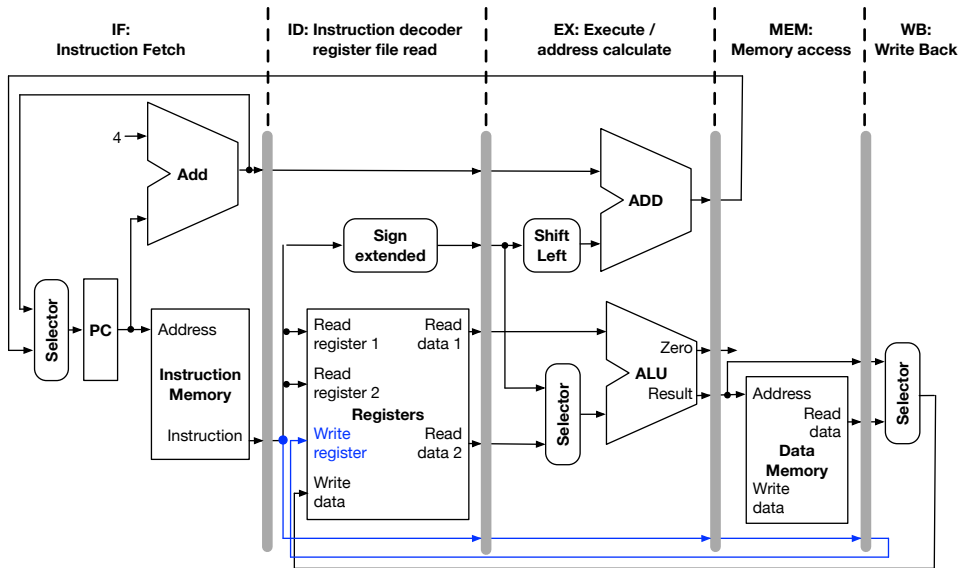



# Pipelined control

# Pipelined Control

- ▶ At each stage, information from instruction is needed
  - ▶ which ALU operation to execute
  - ▶ which memory address to consult
  - ▶ which register to write to
- ▶ This control information has to be passed through stages

# Pipelined Control

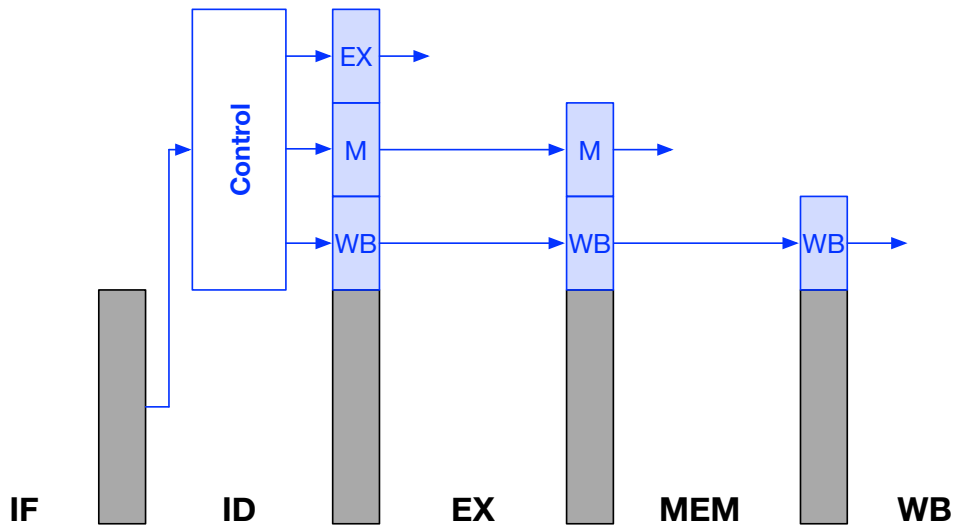

# Control Flags

